



**Splash and Dash**<sup>®</sup>  
Groomerie & Boutique



# BRAND BUILD STANDARDS



# DISCLAIMER:

ALL DIMENSIONS ARE ESTIMATES PROVIDED BY THE CORPORATE OFFICE. THESE ARE GENERAL ESTIMATIONS BASED ON THE SQUARE FOOTAGE PROVIDED BY THE RETAIL SPACE OWNER. DESIGNS MY BE SUBJECT TO CHANGE BY ARCHITECT.

# TABLE OF CONTENTS

## The Contractor

Disclaimer .....	3
Architectural Plans:.....	4
Table of Contents.....	5
Store Front Floorplan.....	7
Store Back Floorplans.....	8
Drop Ceiling Detail.....	9
Store Floor Details.....	10
VCT Floor Design.....	11
Bathing Room: Drying Stations.....	12
Bathing Room: Drying Stations.....	13
6' Drying Station.....	14
3' Drying Station.....	15
Drying Station Assembly / Materials.....	16
Sound Proofing.....	17
Fire Sprinklers/HVAC System.....	18

## The Electrician

Materials .....	19
Material Descriptions .....	20
Store Front Electrical Outlet Plan .....	22
Store Front Electrical Lighting Plan .....	23
Store Front Lights.....	24
Store Back Drop Ceiling Lighting.....	25
Store Back Electrical Outlet Plan.....	26
X-Power Air Dryer (Kennel Room).....	27
Electrician - Drying Table Details (Bathing Room).....	28

## The Plumber

Store Back Plumbing Plan .....	30
Bathing Stations.....	31
Bathing Station Assembly.....	32
Hot Water Heater Details.....	33

## The Painter

Wall Paint Colors .....	35
Wall Paint Colors - Cont'd.....	36
Wall Mural Installation.....	37

## Miscellaneous

Miscellaneous - Q & A.....	39
Retail Desk Construction.....	40
Cycle Dog PAnogram .....	41
Spa Wall.....	42
Nesty Tables.....	43
Fun & Fabulous Wall .....	44
Fun & Fabulous Wall .....	45
Fun & Fabulous Wall.....	45
KiS Treat PAnogram.....	46
Selfie Wall.....	47
Grooming Station .....	48
Grooming Station.....	49
Cages Sizes 11 Unit Cage Bank Kit.....	50
Cages Banks 11 Unit Cage Bank Kit.....	51
Wire Frame 6 Unit Cage.....	52
Plumber - Materials.....	53

# DISCLAIMER

All plans and illustrations contained in this publication are the exclusive property of SD Franchise LLC, dba Splash and Dash Groomerie & Boutique and reproduction in whole or in part is strictly prohibited by law.

All information and construction plans contained within this document are provided AS IS. SD Franchise LLC, disclaims all other warranties, express or implied, including merchantability or fitness of purpose. Construction plans must be submitted to a local architect for approval. SD Franchise LLC is not liable for incidental, special, consequential, or indirect damages of any kind, including, but not limited to, loss of anticipated profits, business opportunity or other economic loss arising out of the use of services or any construction plans received from SD Franchise LLC, even if SD Franchise LLC has been advised of the possibility of such damage.

It is the franchisee's responsibility to ensure the accuracy, compliance with applicable statute(s) or regulation(s), and fitness of purpose of any plans or construction information received from SD Franchise LLC prior to the use thereof.

## Information on Building Codes:

SD Franchise LLC, does not assume any knowledge of local, state or federal building codes. All plans MUST be reviewed by a local professional architect or engineer before the start of construction or such services that are best handled by those familiar with your local building codes.

## Plan Usage

1. All plans are protected by Federal Copyright Laws. Any use of the information contained herein beyond the one-time use authorized by SD Franchise LLC, of prints, or any duplication, publication, sale or distribution of any part of these plans without the prior written consent of SD Franchise LLC Designer represents a violation of Federal Laws subject to the prescribed penalties.
2. Any use of the plans, or modifications of the plans, by Franchisee, builders or others is done at their own risk. Franchisee should have the plans reviewed by a local professional architect or engineer before the start of construction. The information contained within the construction documents is intended to depict design and basic construction detailing. It is the builder's responsibility to provide standard construction details and practices which will result in a structurally sound and weatherproof finished product.

## Plan Content

These Plans provide ideas and concepts and are not intended to be complete in all respects and details. Variations in standard sizes of window and door brands and types and use of different materials and thicknesses can change details. Varying local codes, ordinances, regulations, foundation requirements, and the layout of electrical, mechanical, and plumbing systems can also change details.

## Responsibility of Builder/Contractor hired by Franchisee

1. It is the responsibility of the builder to assure that all work is in accordance with the latest edition of all applicable Nation, State, and Local Building Codes. It is the builder's responsibility to ensure that all work is conducted in accordance with the latest edition of all applicable Construction Standards.
2. It is the responsibility of the builder to ensure that all manufactured articles, material, and equipment are applied, installed, connected, erected, used, cleaned, adjusted, operated and conditioned as directed by the manufacturers. Builder shall follow all instructions to sustain and preserve all expressed or implied warranties and guarantees.
3. It is the responsibility of the builder to assure that all materials, equipment and components are new and of good quality.
4. It is the responsibility of the builder to check all dimensions and details for overall accuracy appropriate to the local conditions and the final selection of materials such as masonry, floor joists, lumber, structural members, construction panels, roofing, etc., all of which can create variations in dimension and detail. For example, if standard lumber joists are used in place of engineered floor joists, the floor-to-floor dimension would vary from the plans and require revised stair dimension and framing.

# ARCHITECTURAL PLANS:

## **Architectural Plans:**

The use of an architect may or may not be required based on local municipalities. The general contractor will provide guidance on the local requirements. In the event one is required to obtain building permits, the franchisor recommends giving a copy of this packet to the architect. Also, supply the architect with our contact information should he/she/they have any questions.

- **Dan Barton - dan@sd4d.com**

## **Local / Governmental Permits:**

Knowledge of obtaining local building permits is the responsibility of the general contractor. He/she is responsible for obtaining all necessary permits to move the project forward.

## **Section One:**

All Tasks in this section are to be completed by:

# **The Contractor**

# STORE FRONT FLOORPLAN

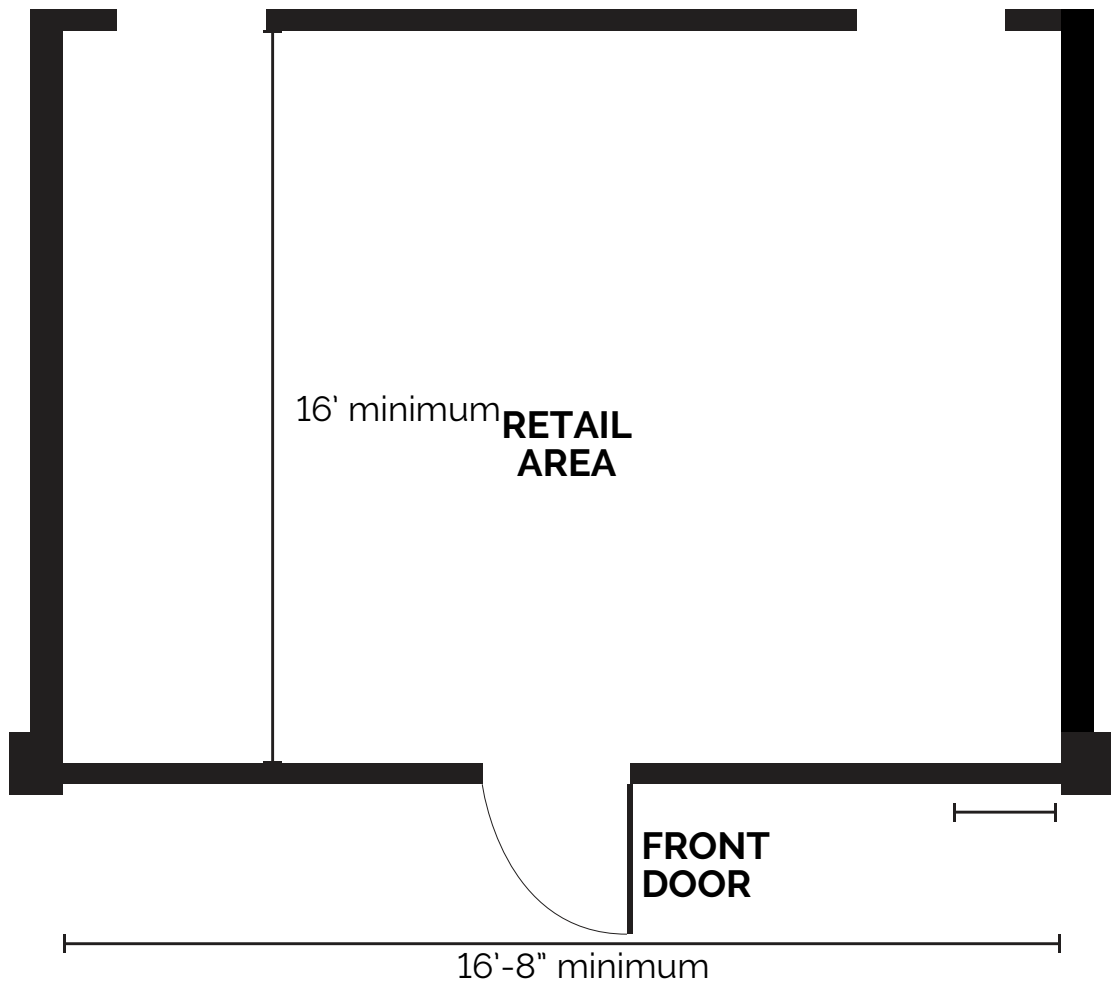

# STORE BACK FLOORPLANS

*\*Layout varies by location.*





# DROP CEILING DETAIL



## **FRONT RETAIL SECTION**

- Standard Drop Ceiling
- Black Frame
- Black Tiles

***FRONT SECTION MUST BE BLACK ON BLACK***

## ***BACK SERVICE SECTION***

- Standard Drop Ceiling
- Black or White Frame
- Black or White Tiles (*Whichever is LESS expensive - Black or White*)
- Duraclean smooth vinyl tiles for bathing room or cement board

# STORE FLOOR DETAILS

## FLOOR - VCT TILE THROUGHOUT (FRONT & BACK)

Imperial Texture VCT 12" x 12"

(W)		Vinyl Composition Tile <b>Imperial Texture 51941 Polar White</b> 12" x 12"
(G)		Vinyl Composition Tile <b>Imperial Texture 57510 Kickin Kiwi</b> 12" x 12"
(R)		Vinyl Composition Tile <b>Imperial Texture 57514 Shocking</b> 12" x 12"
(B)		Vinyl Composition Tile <b>Imperial Texture 57535 Blue Moon</b> 12" x 12"
(CB)		Vinyl Composition Tile <b>Imperial Texture 51910 Classic Black</b> 12" x 12"

## ADHESIVE

- Armstrong S-515 Tile Strong

## FLOOR CARE & REPAIR

- **Floor Polish:** Armstrong S-480
- **Floor Cleaner:** Armstrong S-485
- **Floor Sealer:** Armstrong S-495

## WAX DETAILS

- 3-5 coats of wax with 1-2 coats of sealer

# VCT FLOOR DESIGN

## FLOOR - VCT FLOOR DESIGN IN RETAIL AREA ONLY

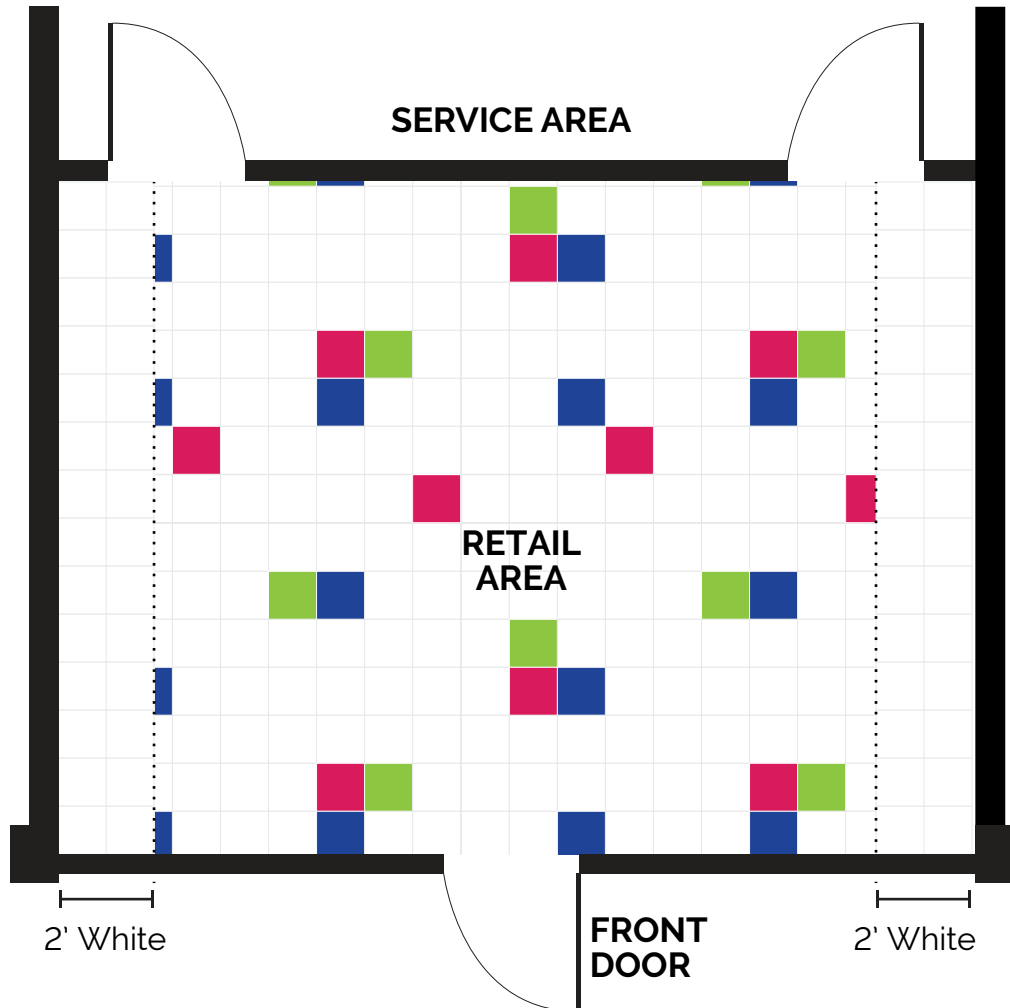

### PATTERN

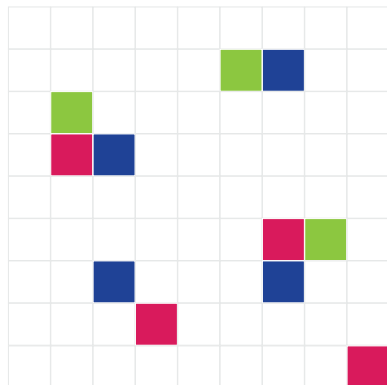

W	W	W	W	W	W	W	W	W	W
W	W	W	W	W	G	B	W	W	W
W	G	W	W	W	W	W	W	W	W
W	R	B	W	W	W	W	W	W	W
W	W	W	W	W	W	W	W	W	W
W	W	W	W	W	W	R	G	W	W
W	W	B	W	W	W	B	W	W	W
W	W	W	R	W	W	W	W	W	W
W	W	W	W	W	W	W	W	W	R

(Graphic Reference for B/W document)

-Corporate will provide color tiles per blueprint

# BATHING ROOM: DRYING STATIONS

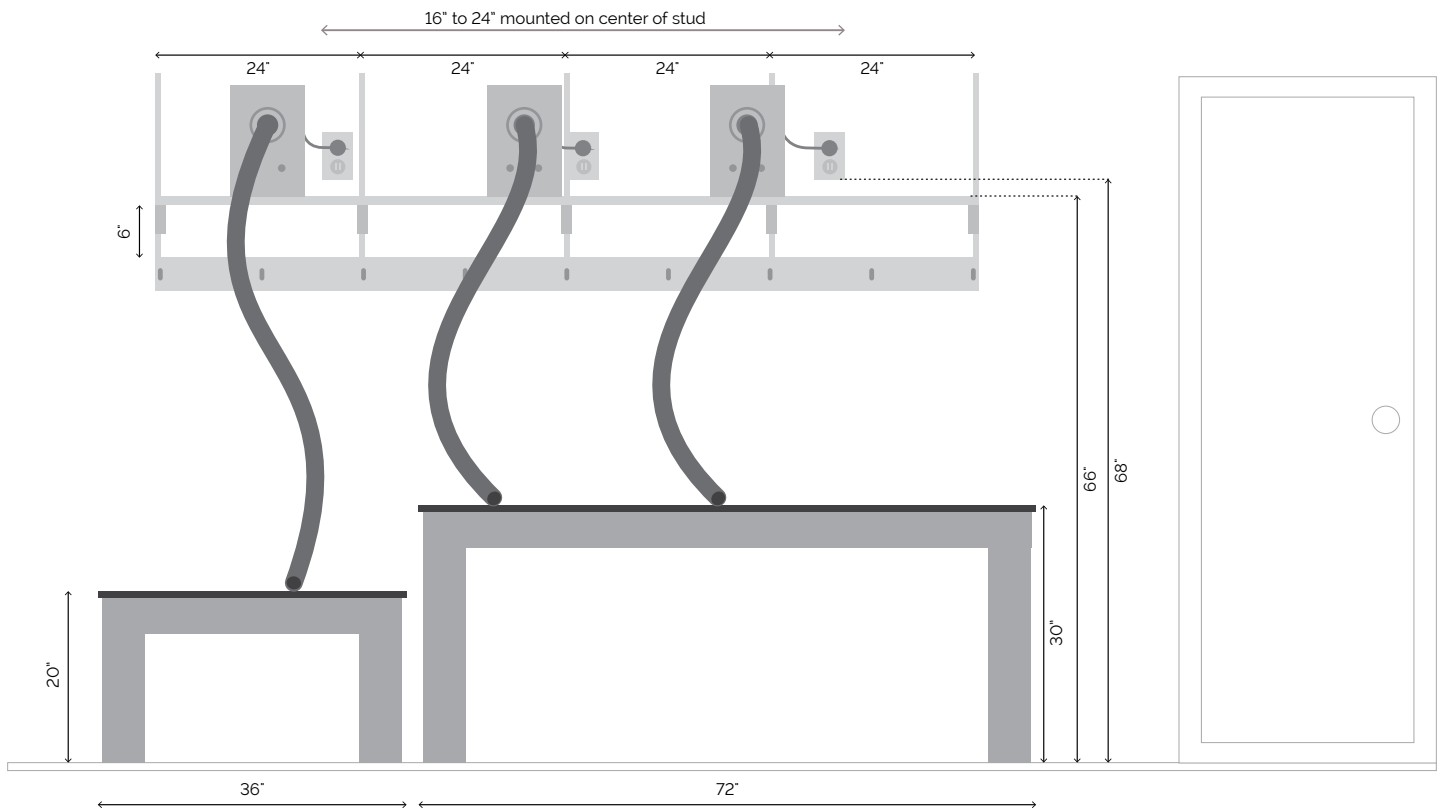
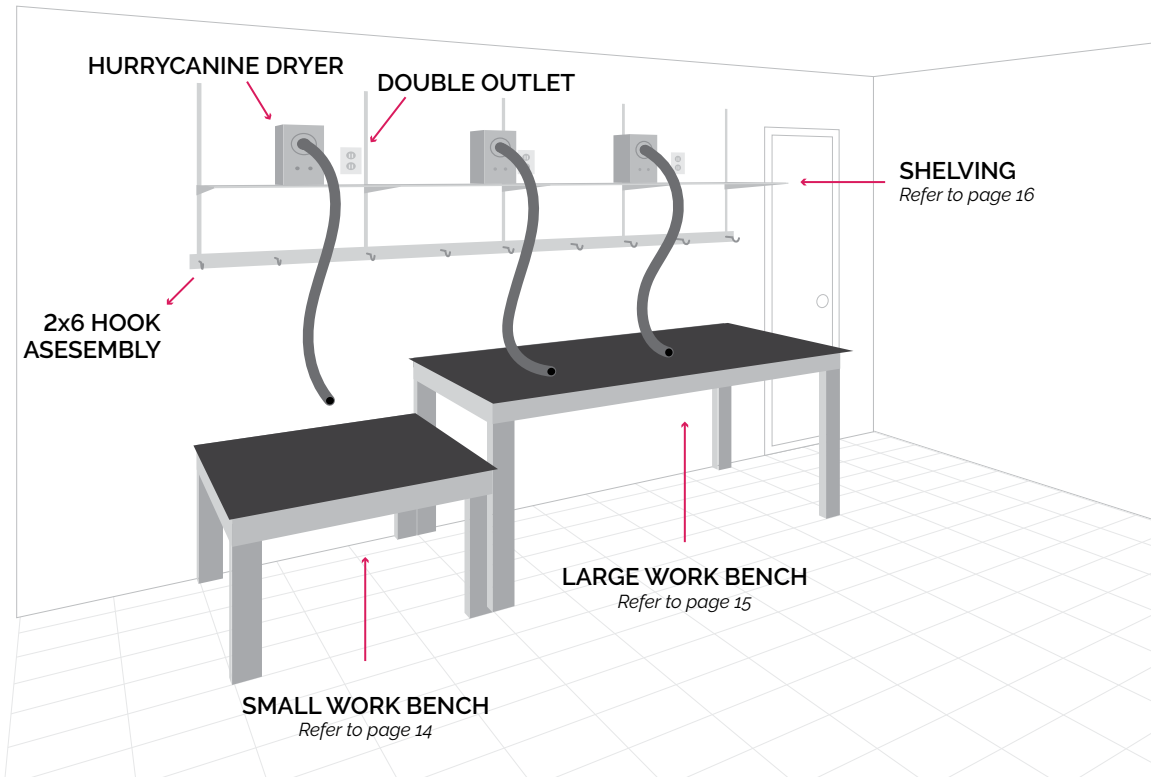

# BATHING ROOM: DRYING STATIONS

**!** *Wire shelf installed upside down to create lip to keep dryers from sliding*

- Wired Closet Shelving from Lowe's or Home Depot
- Drying Table hook assembly
  1. Mock up the 2x6 by placing it in the shelf mounts and marking where mounts line up on the 2x6.
  2. Mark 2 screw hook locations in between each mount.
  3. Drill all of your holes on the 2x6 before you hang so you can secure through pilot holes
  4. After you drill, place the 2x6 in the mounts and mark on steel mounts through the pilot holes
  5. Use 3" steel screws so you can reach through the 2x6, shelf mounts, and stud. Secure with a washer

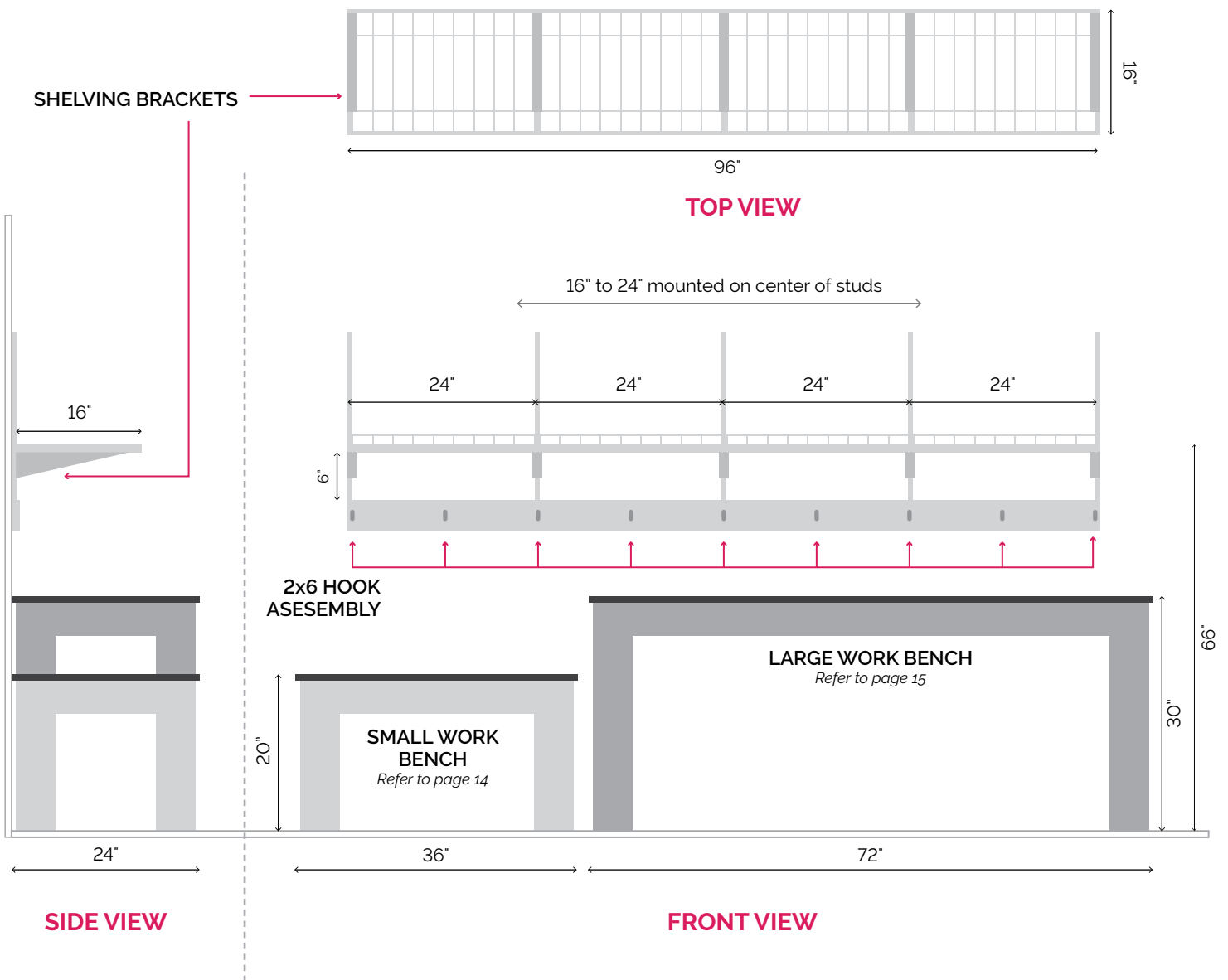

# 6' DRYING STATION

## LARGE

\*Built by Contractor using Pressure Treated Wood

\*Vary in length and quantity by location blueprint

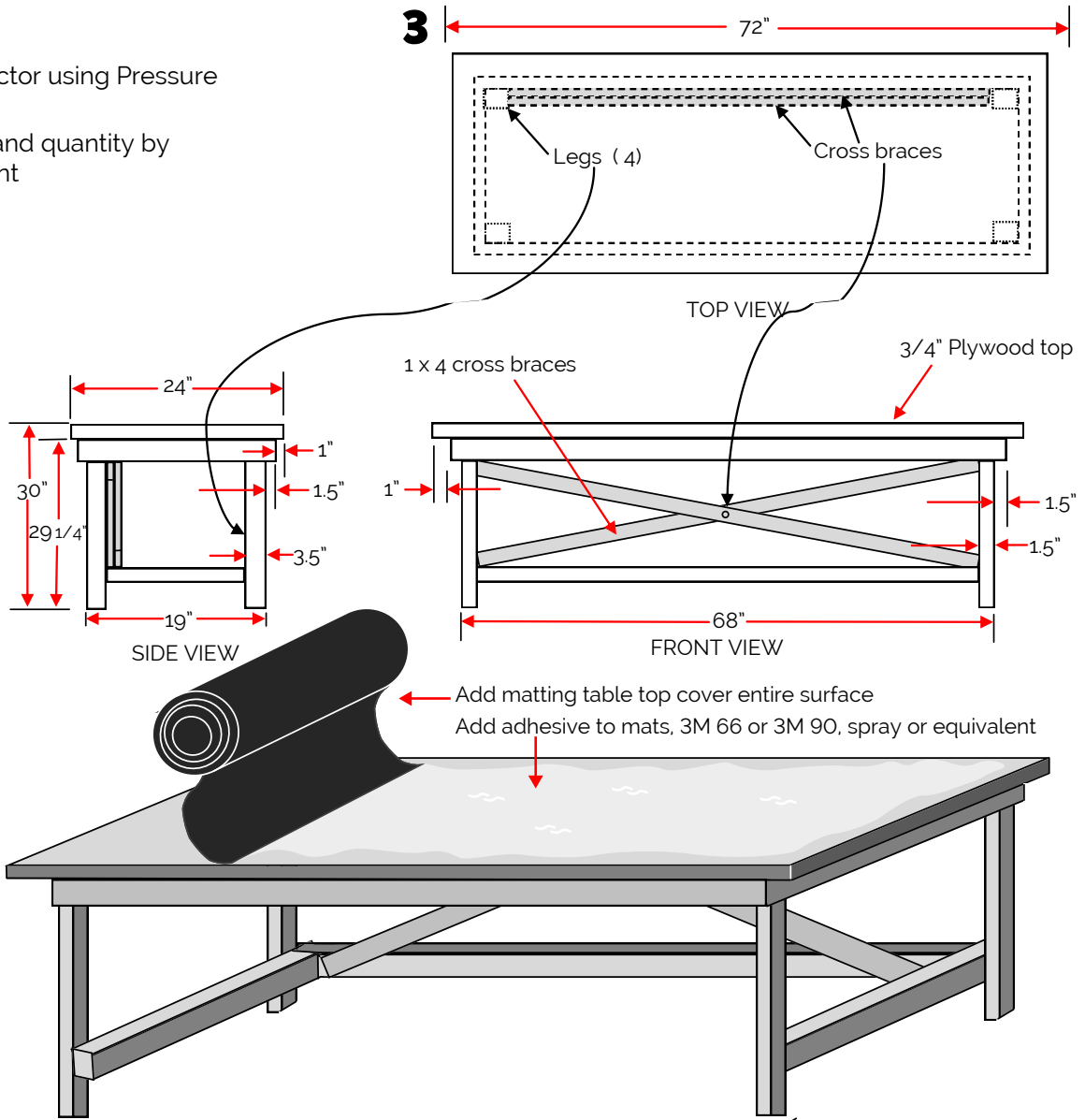

**All Pressure Treated Lumber**

KEY:

- = Plywood Table top
- = 2x4's
- = 1 x 4 boards
- = 2 x 6 Hook Assembly
- ← Assmbl' 1x4's
- ← Assmbl' 2x4's
- ← Assmbl' top

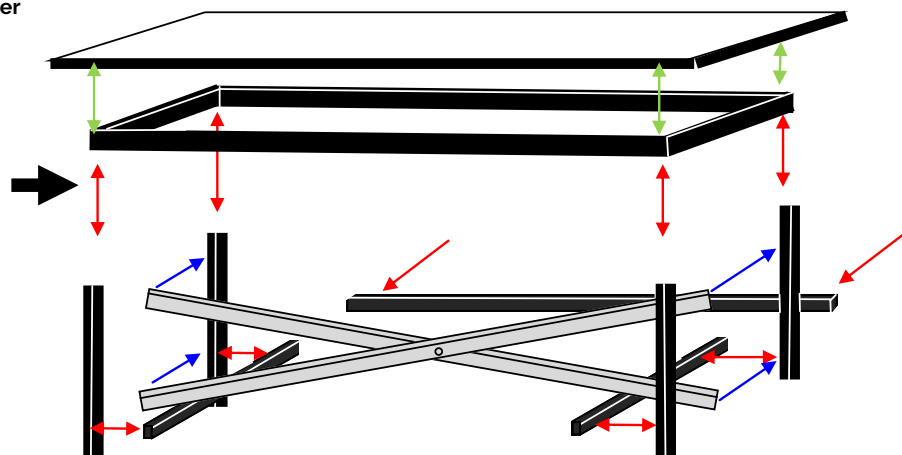

# 3' DRYING STATION

## SMALL





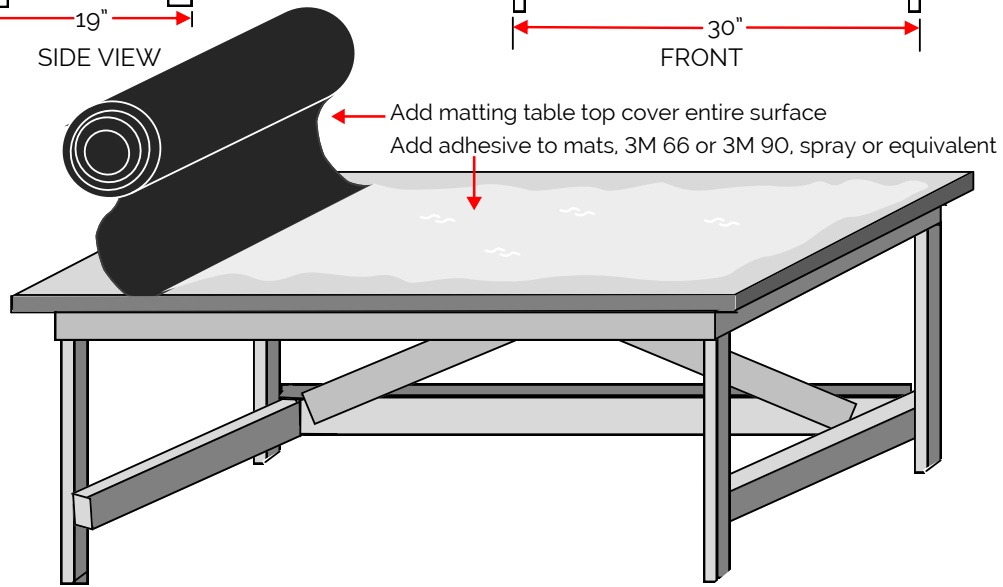
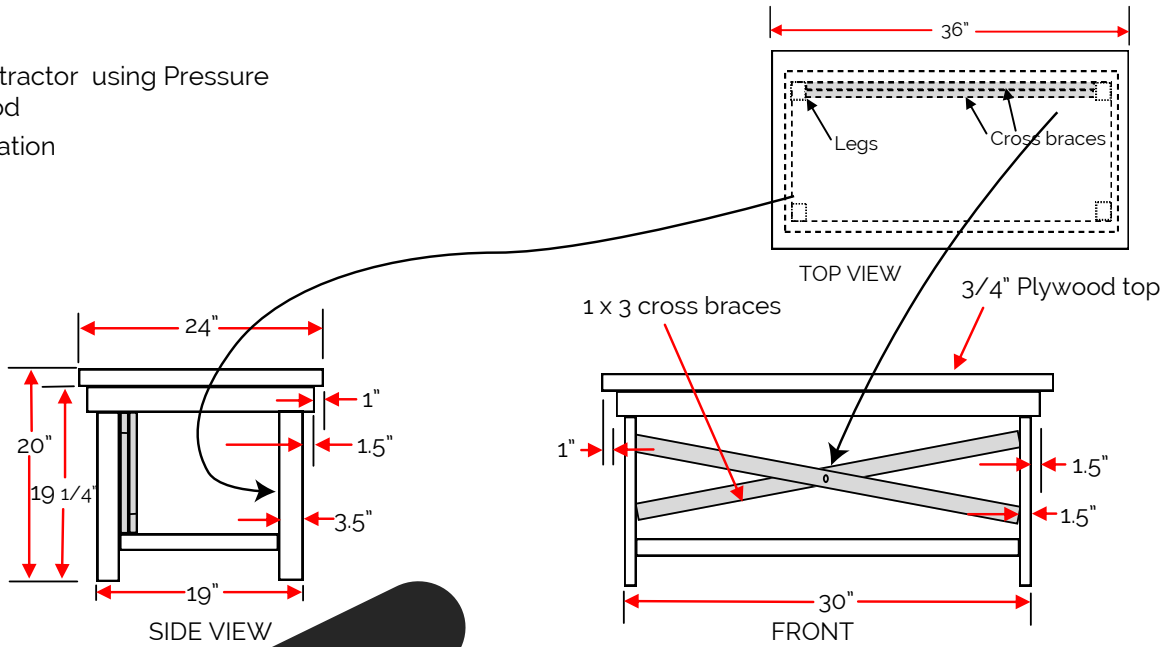

\*Built by Contractor using Pressure Treated Wood

\*Vary by Location



**All Pressure Treated Lumber**

**KEY:**

-  = Plywood Table top
-  = 2x4's
-  = 1 x 4 boards
-  = 2 x 6 Hook Assembly
-  ← Assmbl' 1x3's
-  ← Assmbl' 2x4's
-  ← Assmbl' top

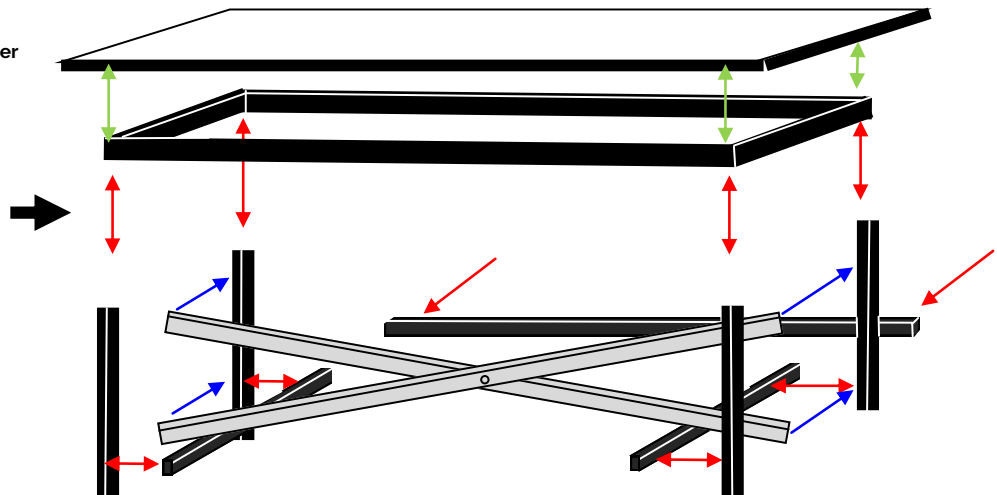

# DRYING STATION ASSEMBLY / MATERIALS

**\*NOTE: Must order prior to assembly - [AmericanFloorMats.com](http://AmericanFloorMats.com)**

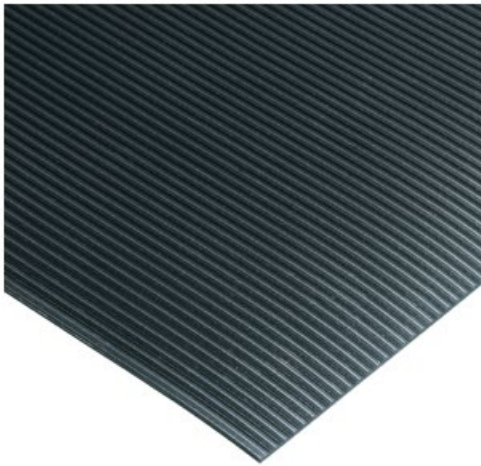

## CORRUGATED RUBBER RUNNER MATS - ITEM # VCRUR

SoundSafe 4.5ft. x 20ft. Soundproofing Acoustic Insulation Roll

- Corrugated rubber mats can greatly increase traction and thus help prevent slips and falls while offering greater flexibility.
- These 100% nitrile rubber runner mats are manufactured for heavy traffic and ideal in wet areas. These runner mats resist curling & warping.
- Rubber runners create a barrier to cold flooring substrates and can also quiet footsteps over noisy tiled areas. Corrugated rubber matting can also be used as a liner for maintenance and tool carts.
- 2', 3' and 4' mats are available up to 150' long. However, 6' wide mats and all 1/4" thick mats are available up to 75' long.



Mock up the 2x6 by placing it in the shelf mounts and marking where mounts line up on the 2x6.

Mark 2 screw hook locations in between each mount.

Drill all of your holes on the 2x6 before you hang so you can secure through pilot holes

After you drill, place the 2x6 in the mounts and mark on steel mounts through the pilot holes

Use 3" steel screws so you can reach through the 2x6, shelf mounts, and stud. Secure with a washer





# SOUND PROOFING

## Sound Proofing:

Sound proofing is not required by the Franchiser. This is an option that needs to be discussed with the Franchise Owner and in guidelines with what is required /outlined within the lease. In the event sound proofing is required, then the franchiser would recommend the following product, or something similar, based on lease requirements. Sound engineer determines requirements.

## SOUND PROOFING

SoundSafe 4.5' x 20' Soundproofing Acoustic Insulation Roll

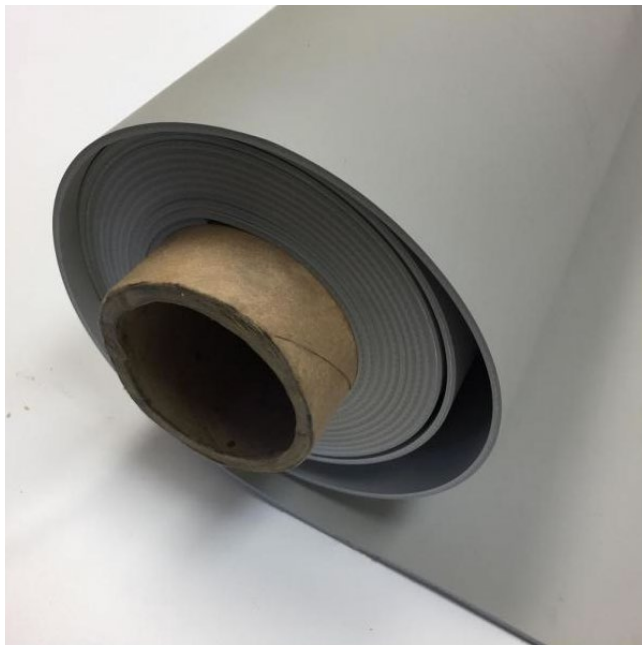

- Vinyl construction for strength and durability
- Reduces noise transmission
- Can be screwed, stapled, glued, taped or fastened to the edges

### MINIMUM REQUIREMENTS

- Drywall + Quietrock
- Inch air gap insulated
- Insulation above ceiling

# FIRE SPRINKLERS/HVAC SYSTEM

## Fire Sprinkler System -

Fire Sprinkler System modifications, based on local code, should be provided by the project architect. The Franchisor is willing to modify the floor plan to help save cost by utilizing the existing sprinkler system. Should this be necessary, prior approval from the Franchisor is required.

## HVAC System -

HVAC system modification for the proper air flow should be provided by the project architect. A minimum of 1 supply and return should be in every room. See architectural plans for more details.

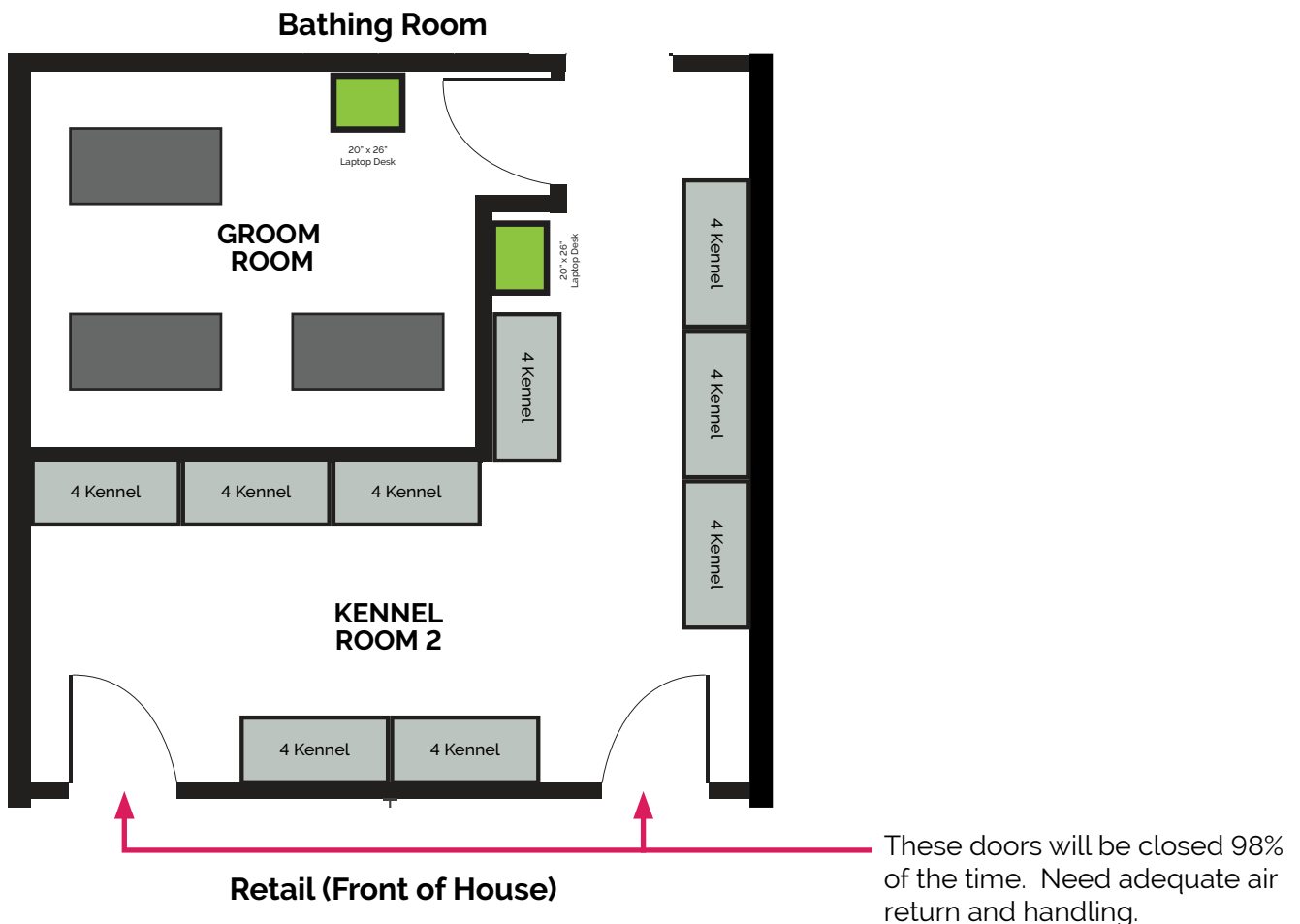

# MATERIALS

## MATERIALS :

The materials required for completing this project can all be purchased from a local home improvement store. The franchisor's goal is to minimize costs and ensure materials are easily accessible. Contractors can purchase necessary materials from approved suppliers as needed.

Below are our recommendations for certain products:



### **Windowed Doors**

36 in. x 80 in. Primed  
Composite Clear Glass 10 Lite True Divided  
Single Prehung Interior Door

#### **These doors will be installed:**

- Bathing Room into the Kennel Room Door
- Hallway into the Kennel Room Door
- Grooming Room into Kennel Room 2
- Kennel Room 2 into Kennel Room 1

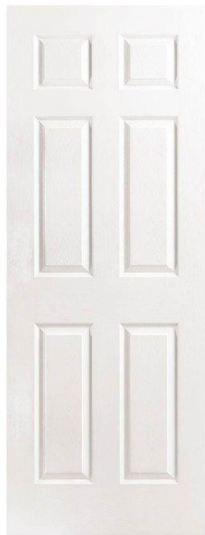

### **Standard 6 Panel Doors**

36 in. x 80 in. 6 Panel.

#### **These doors will be installed:**

- Manager's Office Door
- Doors from Retail Area to the back
- Restrooms, if not existing
- Wood texture finish acceptable

# MATERIAL DESCRIPTIONS



### Wire Shelf - ClosetMaid

16" Deep White Ventilated Wire Shelf

**This will be installed upside down in the bathing room to create a lip so the dryers don't slip off the shelf. Installation should look similar to picture, with the lip pointing up.**



### Bathing Room Wall Covering

4 ft. x 8 ft. Plastic Panel Installed in bathing room on all the walls. FRP Panels must be installed from floor to ceiling (*FRP Panels Smooth*)

**May need to be cut to fit.**



### Black Vinyl Wall Cove Base

4" tall.

**May need to be cut to fit.**



### Door Hinges - Everbilt

3-1/2 in. x 5/8 in. Radius Satin Chrome Adjustable Spring Door Hinge

**All Doors in retail and service space MUST be equipped with these self-closing hinges.**

- Both Doors from Retail Area to Back of Shop
- Bathing Room Door (s)
- All Kennel Room Door (s)
- Grooming Room
- Break Room



### Door Knobs - Hartford Satin Nickel Passage Hall/Closet Door Knob

All doors must be equipped with knobs. Handles can be operated by dogs.

## **Section One:**





All Tasks in this section are to be completed by:

# **The Electrician**

# STORE FRONT ELECTRICAL OUTLET PLAN

· **NO SWITCHES**  
 · **NO THERMOSTATS**  
 · **NOTHING ON FORWARD FACING MURAL WALL**

## Legend

-  Double Outlet
-  Quadruple Outlet
-  Light Switches (4)
-  Thermostat  
*(Above light switch to not interfere with FF&E Placement)*

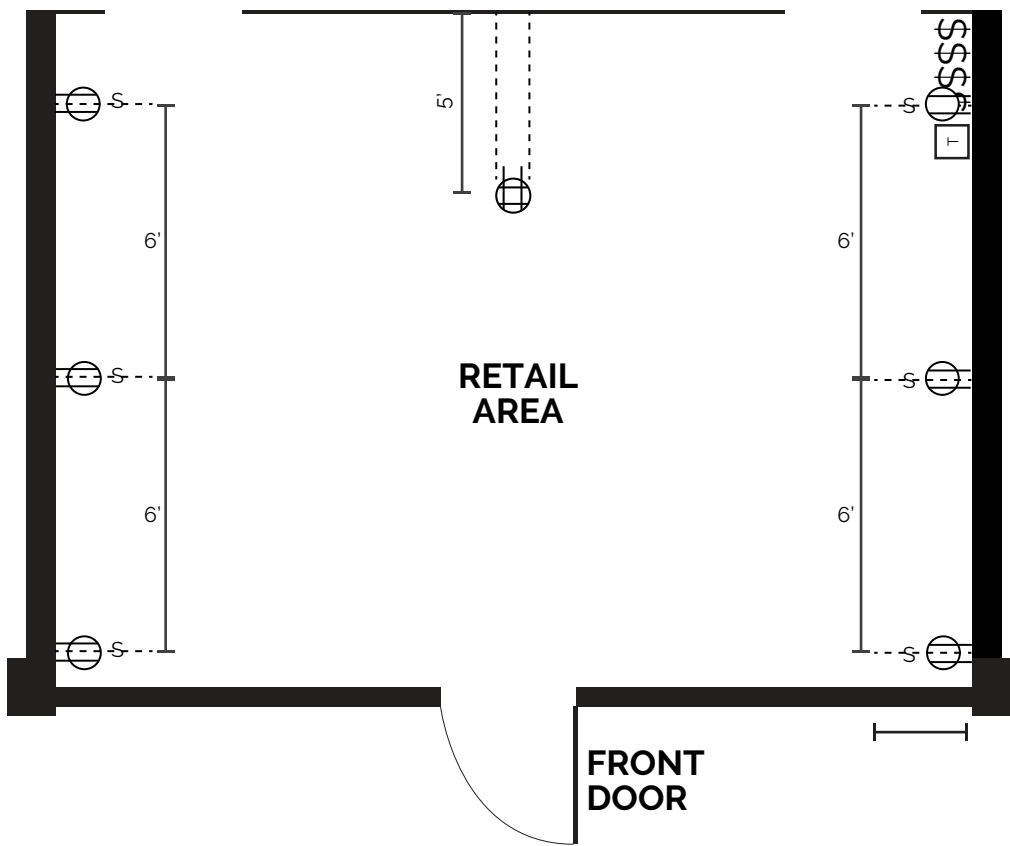



## Notes

- All Outlets aligned Vertical
- All Outlets need 18 inches to the bottom of the plates Above Finished Floor **as allowed by local codes.**

# STORE FRONT ELECTRICAL LIGHTING PLAN

- **NO SWITCHES**
- **NO THERMOSTATS**
- **NOTHING ON FORWARD FACING MURAL WALL**

## Legend

-  IKEA - SKURUP  
Bulb Track Light  
103.959.30  
Ceiling track, 3  
spotlights, black
-  IKEA - MELODI  
Pendant Light  
603.865.32  
Pendant lamp, white, 11 "
-  Chandelier  
*\*Provide by Corp*

## Notes

Track Lighting - Bulb direction is always towards the wall, with the swivel dead zone away.

For example:

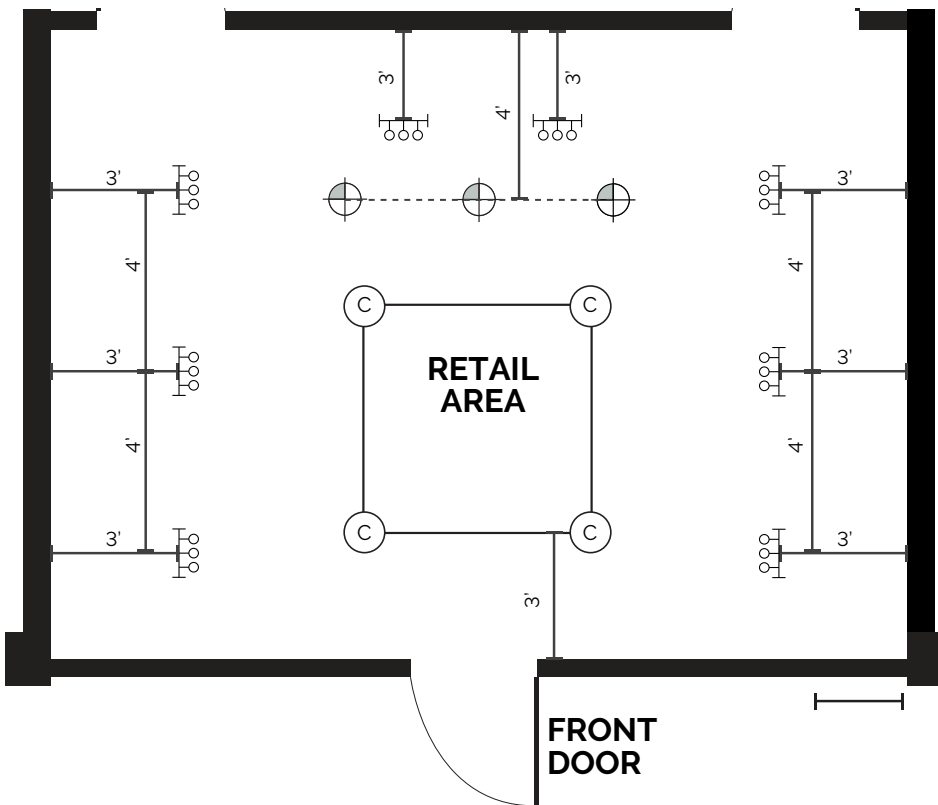

# STORE FRONT LIGHTS

**NOTE:** Turnaround time for receiving corporate supplied lighting fixturing is 14 days. Please email Sean@sd4d.com with a date contractor wants lighting fixture on-site.

## Supplied by contractor



IKEA - SKURUP  
Bulb Track Light  
103.959.30

**Note:**  
**Track Lighting - Bulb direction is always towards the wall, with the swivel dead zone away from wall.**



Option 1  
IKEA - BUNKEFLO  
Pendant lamp,  
white/birch, 14 "  
104.883.97



Option 2  
IKEA - MELODI  
Pendant lamp,  
white/birch, 11 "  
603.865.32

**Note:**  
**Bottom of Pendant Lights should be 36" above desk center, or 71 3/8" Above Finished Floor.**

## Supplied by corporate

### Product Specifications



#### Specifications

Type: Pendant Light  
Suggested Space Fit: Bedroom, Living Room  
Finish: Electroplated  
Light Direction: Ambient Light  
Suggested Room Size: 20-30m<sup>2</sup>  
Style: Drum, Modern/Contemporary  
Voltage (V): AC110-240  
Dimmable: No

**Dimensions**  
Fixture Height (CM): 30  
Fixture Width (CM): 45  
Fixture Length (CM): 45  
Chain/Cord Length (CM): 60  
Chain/Cord Adjustable or Not: Chain/Cord Adjustable

**Bulb Information**  
Bulb Base: E12/E14  
Bulb Type: Incandescent  
Number of Bulb: 4 Bulb  
Wattage per Bulb (W): 40  
Bulb Included or Not: Bulb Not Included

**Material**  
Fixture Material: Metal  
Shade Material: Fabric  
Decoration Material: Acrylic

**Weights**  
Net Weight(kg): 5.1



# STORE BACK DROP CEILING LIGHTING

## DROP CEILING LIGHTING - CONTRACTOR PROVIDED

Contractor Select GT 2 ft. x 4 ft. Integrated LED 4000 Lumens 4000K 120V Commercial Grade Recessed Troffer or equivalent.



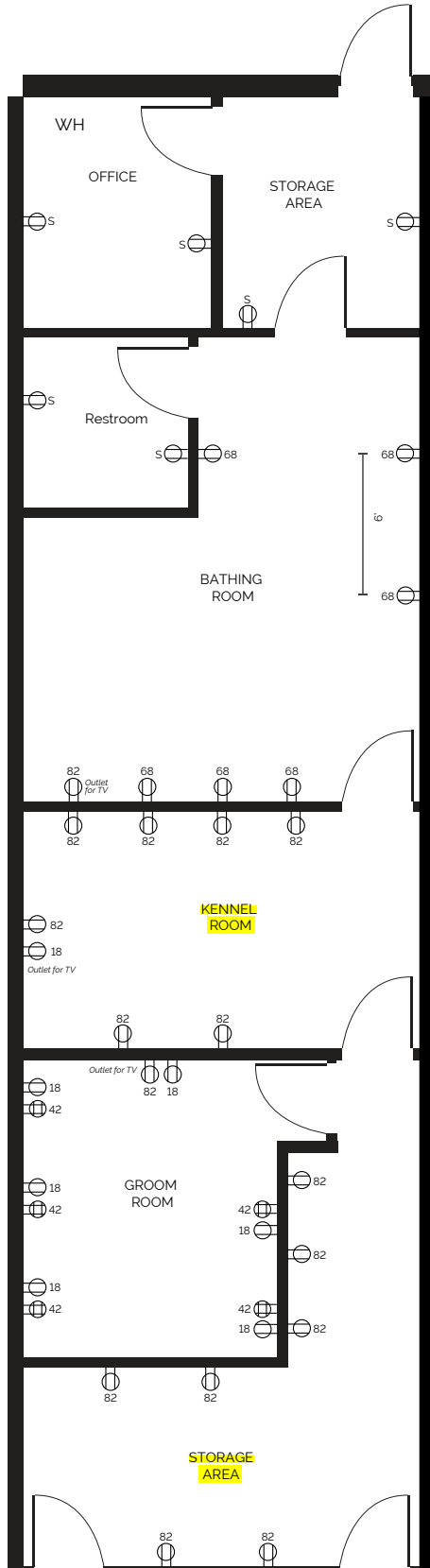

- 29-Watt, 4000K cool white light produces 3980 lumens
- Lay in design for T-Grid and acoustic drop ceiling applications
- Rated for 72,000 hours, DLC qualified and 5-year limited warranty

# STORE BACK ELECTRICAL OUTLET PLAN



## Legend

-  Double Outlet
  - 82" above floor
  - 72" above floor
  - 68" above floor
  - 18" above floor
-  Quadruple Outlet
  - 42" above floor
-  Water Heater Connection

## Notes

### Retail

- All Outlets aligned Vertical
- All Outlets need 12"-18" to the bottom of the plates Above Finished Floor as allowed by local codes.

### Bathing Room

- All GFCI Outlets in Bathing Room need 68" to the bottom of the plates Above Finished Floor.

### Grooming Room

All Quadruple Outlets in the Grooming Room need to be positioned 42" above the Finished Floor, and Double Outlets should be 18" above.

### Kennel Room

- All GFCI Outlets in Kennel Room need 82" to the bottom of the plates Above Finished Floor.

*\*Refer to elevations in blueprints*

# X-POWER AIR DRYER (KENNEL ROOM)

## X-800TF AIR MOVER

### \*IMPORTANT NOTE:

This location will have 2 of the these dryers up to 4 after opening running simultaneously, each drawing 7.5 amps, 115VAC/60 HZ

- Three different angles of air flow (horizontal, vertical, and 45°), and optional 4th position using a swing-out kickstand.
- Has 3 speeds and ETL Certified.
- High impact Roto-Molded polyethylene casing for durability.
- Energy efficient, **drawing 7.5 amps** with safety locks for use with ducting kit (mdk).
- Anti-skid rubber for secure placement.
- 3200 CFM air volume



# ELECTRICIAN – DRYING TABLE DETAILS (BATHING ROOM)

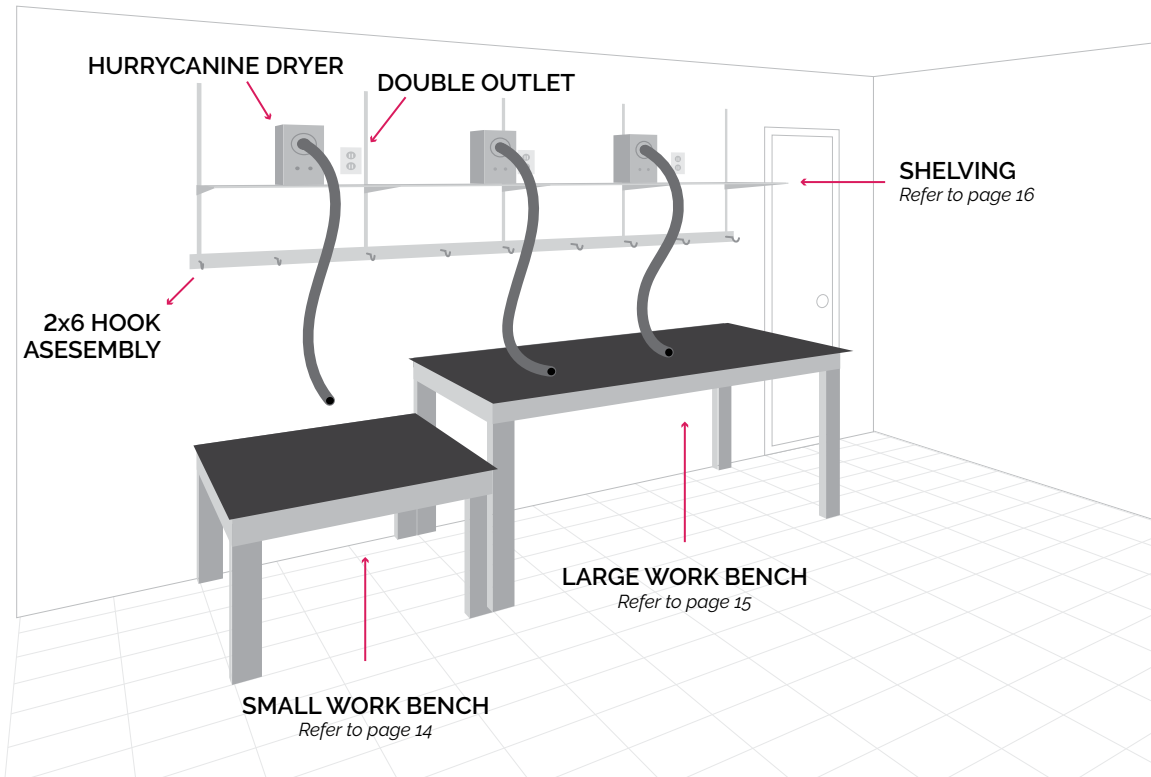

## \*IMPORTANT NOTE:

- This location will have 2 of the these dryers. Each dryer is 20 amps
- They should be laid on their side for safety



## Regular Dryer Manufactured by HURRYCANINE

**20 Amps**  
**Heavy Duty Galvanized**  
**Steel**  
**192 CFM 2 Speeds**

**One Year Warranty**  
**14" L x 15 1/4" T x 8" W**  
**1 1/2" W x 8 1/2' L Hose**  
**24 Lbs.**

## **Section One:**

All Tasks in this section are to be completed by:

# **The Plumber**

# STORE BACK PLUMBING PLAN

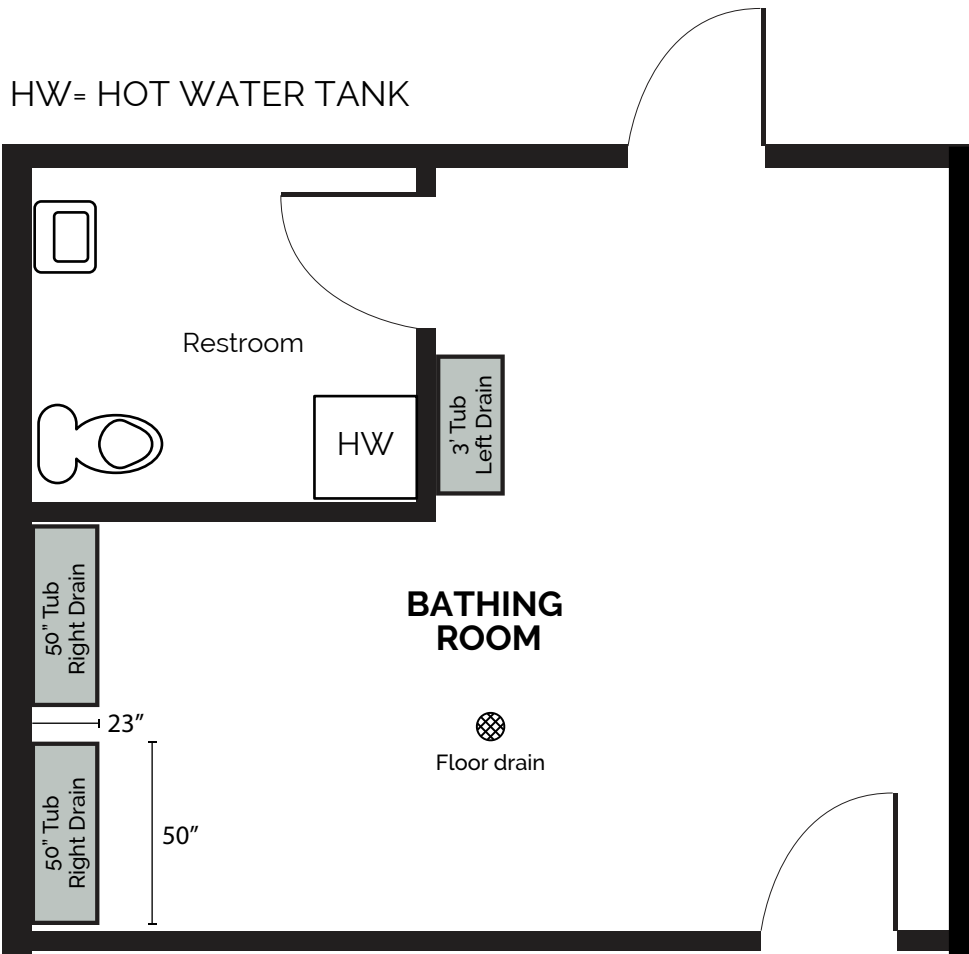

# BATHING STATIONS

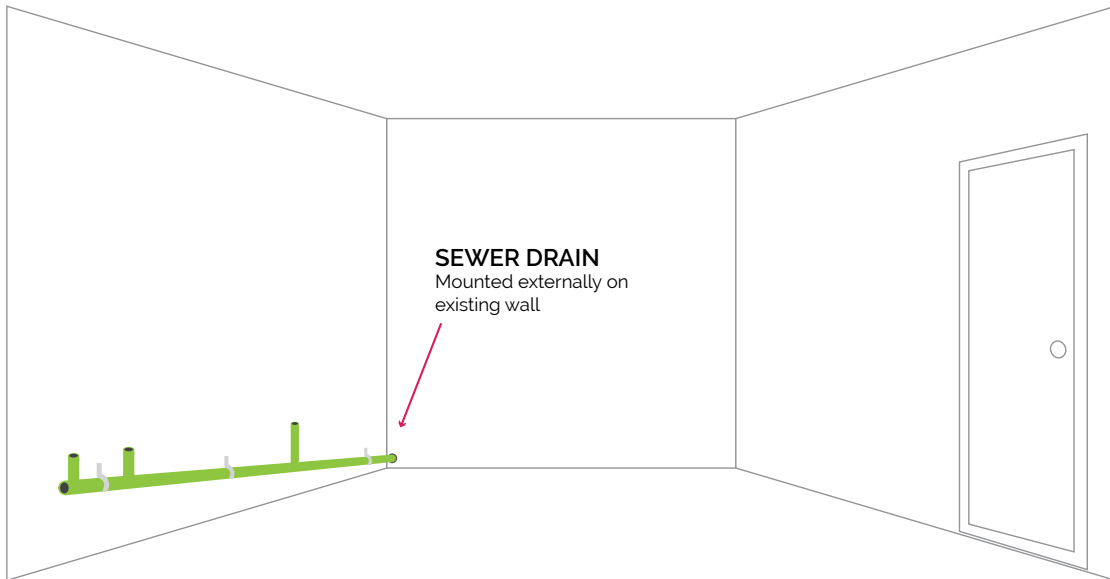

## FUTURE EXPANSION SPOT

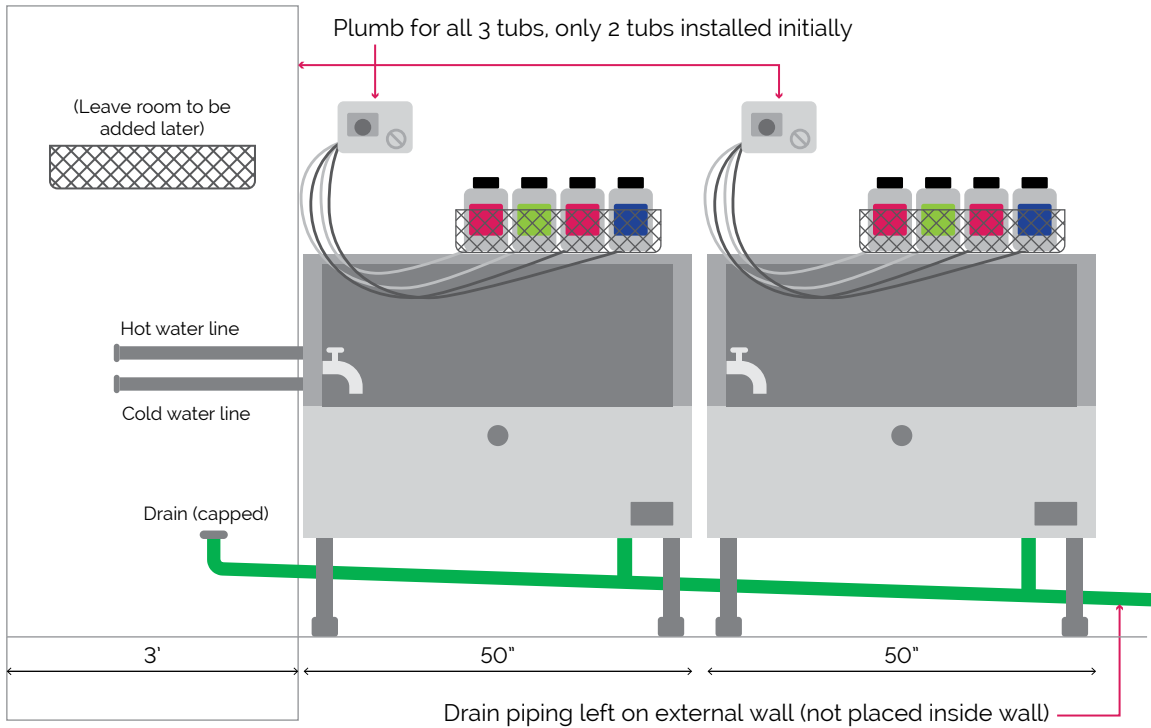

*(Layout may be mirrored if bathing room is on the right side of the store)*

# BATHING STATION ASSEMBLY

- Assemble the tubs BEFORE MOUNTING the Bather Box and shampoo racks on the wall as to know where the comfortable height above the tub will be.
- Situate so that the shampoo rack is slightly lower than the Bather Box to help the siphon, but still make it within reach to change out shampoos easily.
- Install the Bather Box on the same side as the faucet and 5" above the back wall of the tub, let the rinse hose lay over the right side into the tub.
- The shampoo rack should be placed to the side of the tub when possible and the top of the rack 2" below the top of the tub. If space does not permit, the rack should be directly on top of the tub and the Bather Box should be 7" above the tub.

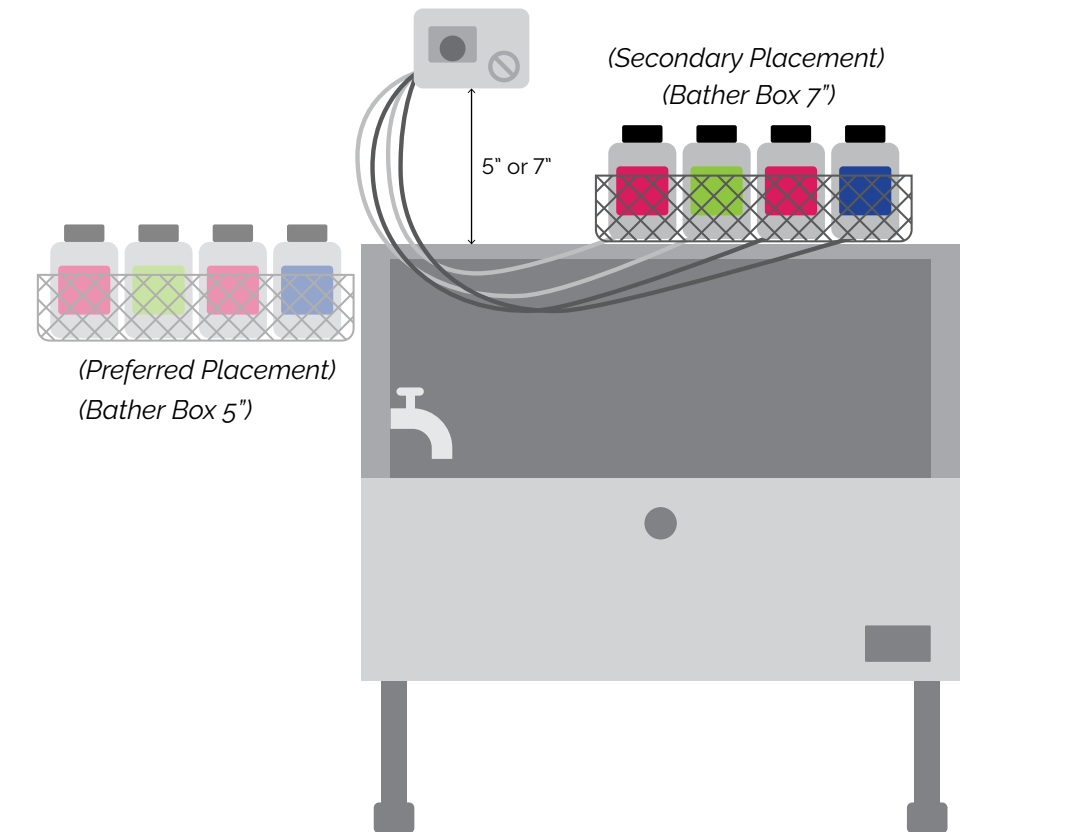



# HOT WATER HEATER DETAILS

## BEST OPTION!



★★★★★  
**Best  
Choice**

80 Gal. Lifetime 12kW  
Electric Water Heater with Durable  
316l Stainless Steel Tank

**Note:** Most water heaters come pre-set to low for our standard operation out of the box. Please adjust temperature to 130F and manage accordingly.

*\*Pictures for reference only. Local availability and codes may differ.*

## Better Option



52 Gal. 5500-Watt Lifetime  
Residential Electric Water Heater  
with Durable 316l Stainless Steel Tank

## Standard Option



Performance Plus 50 Gal. Medium  
9 Year 5500/5500-Watt Elements Electric  
Water Heater with LED Indicator

## **Section One:**

All Tasks in this section are to be completed by:

# **The Painter**

# WALL PAINT COLORS

## Front Retail Area

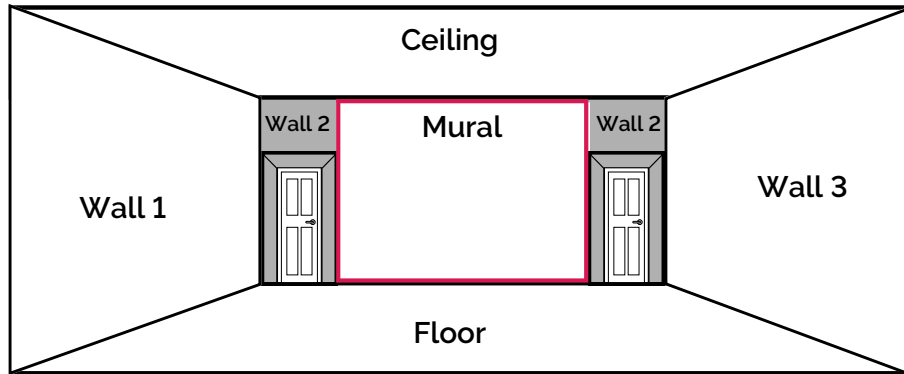

### Front Section Walls

- Wall 1**  
Electric Lime SW 6921
  
- Wall 2, Hallway and Above Hallway**  
Eros Pink SW 6860
  
- Wall 3 & 4 (not pictured, front wall)**  
SW Blue Chip 6959
  
- Mural**  
Primed White Wall trimmed 4" in Pink

### Ceiling

- Splash and Dash Ceiling Black - Flat - Sprayed  
SW 6992

### Doors and Door Frames

- Semi-Gloss White  
SW 7006

### Floor

- Splash and Dash Floor VCT Tile throughout  
Imperial Texture VCT 12 in. x 12 in. Armstrong Flooring  
51914 Polar White Vinyl Tile (45 sq. ft. / case)
  
- Retail Area



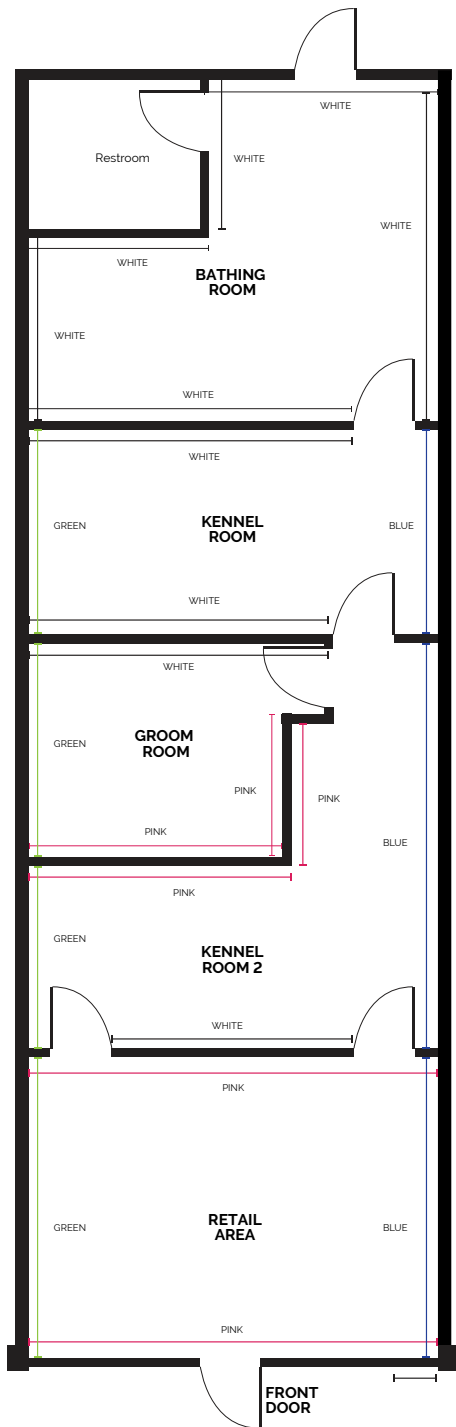

### BOH Walls

- All Interior Walls, unless specified otherwise**  
Semi-Gloss White  
SW 7006

# WALL PAINT COLORS – CONT'D



## SHERWIN-WILLIAMS COLOR CODES

-  **Splash and Dash Primary Blue**  
SW Blue Chip 6959
-  **Splash and Dash Accent Dark Pink**  
Eros Pink SW 6860
-  **Splash and Dash Accent Green**  
Electric Lime SW 6921
-  **Extra White**  
SW 7006

*All Other walls not specified painted Semigloss*

# WALL MURAL INSTALLATION



**STEP 1: PREP YOUR WALL** Proper preparation of your wall is critical! Repair any visible defects, smooth out bumps and patch holes to ensure your wall is smooth and flat. If possible, remove all picture hooks, light fixtures and switch plates. Wash of any dirt, hair, dust or residue from old wallpaper with a dry cloth or a duster. Do NOT use water! A perfectly clean wall will help the adhesive backing to keep its stickiness if repositioning is required.

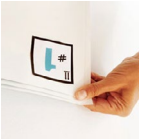

**STEP 2: GETTING READY** Open the sturdy Eazywallz packaging tube. Inside you will find your wall mural. Look for the panel number on the back of each one. Panel#1 is the first panel on the left. Unroll all panels and lay them flat on the floor, the printed side facing the ceiling. You may notice creases and/or bubbles as you unroll the panels. No worries, this is normal. The creases will disappear once the mural is flattened on the wall.

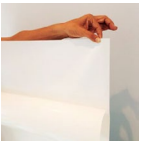

**STEP 3: PEEL YOUR EAZYWALLZ** Peel off the liner a few inches only across the top of the first panel. Do NOT peel off the entire liner all at once.



**STEP 4: STICK IT! (PART 1)** Remember that the success of the installation will depend on properly placing the first panel. Stick the top left corner of the panel to the top left corner of your wall. This is the easiest place to start. Using a smoothing tool or squeegee, smooth the top of the panel onto the wall. Do NOT use pressure to avoid any scratches.



**STEP 4: STICK IT! (PART 2)** Peel off the rest of the panel by gradually and evenly pulling down the liner, a few inches at a time. We recommend having the other person hold the bottom of the panel as you work your way down. Once the first panel is applied, and if necessary, remove any bubbles by gently pushing them outward with the squeegee.



**STEP 5: ADDITIONAL PANELS** Start by aligning Panel#2 to Panel#1. Simply stick the panel against the edge of the first one, by matching the pattern of the mural. Follow STEP 4 above to apply the rest of Panel#2. Repeat the same process to apply all additional panels.

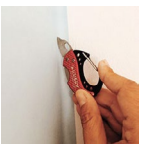

**STEP 6: TRIM OVERAGE** Once all panels have been applied, SLOWLY trim all the overage with an utility knife with a sharp blade (ie: Xacto knife). Follow the edges of your wall or ceiling to do so. You can also use a ruler to cut through a straight line. If needed, repeat this process to cut around outlets, fuse boxes, windows, doors, etc.

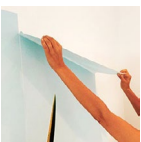

**STEP 7: REMOVAL PROCESS** Slowly and gently pull the panels from the wall. Use your hand to gradually hold back the wall mural during this process. To avoid any damage to your wall while removing, keep the wall mural as flat and parallel to the wall as possible. We highly recommend to keep the backing liner (wax paper), so you can re-apply the wall mural to it. It will protect the adhesive from losing its stickiness and allow you to re-use your wall mural.

# MURAL INSTRUCTION TIPS

- Note the numbers on the back sides of the murals.
- Lay them all out in order on a clean surface and match up the lines and patterns BEFORE taking any sticky backing off.
- After you are sure the pattern is correct, lay your first piece from top to bottom, about 6 inch sections at a time.
- Use something flat, dull, and straight (squeegee, dust pan, plastic paddle, etc.) to get the bubbles out of each section as you adhere it to the surface.
- This should be a two person job. Someone holding the bottom of the mural will help to reduce the amount of bubbles.

# Miscellaneous

# MISCELLANEOUS – Q & A

1. VCT Tile is used in the front and back with 3-4 coats of wax and 1-2 coats of sealer
2. HVAC modification will be determined by the architect and based on local code
3. 4" for interior walls. Insulated for sound is a option of the franchise owner but not required. See local codes and landlord requirements. Door will be basic 6 panel pre hung doors from Home Depot or Lowes
4. Front desk will be constructed and installed by corp not the contractor
5. Brand of bathroom fixtures is left up to the franchise owner. Handicapped accessibility will be determined by architect based on local code
6. Tubs and High Velocity Dryers will be ordered by Corporate and sent or brought to location
7. Hot water tank is franchise owners choice, the larger the better but also more expensive (See examples listed)
8. Exterior changes of the space are typically not allowed based on the lease, thus we do not have any requirements
9. Exterior sign requirements will be spelled out in the lease. Once we have a signed lease we will send the requirements to our sign vendor for production and delivery
10. Bathroom Floor - can use existing, do not need to replace
11. Chandeliers lights will be shipped from corporate. Pendants will be purchased by contractor, in accordance with brand book
12. Trench the floor for Front desk
13. Office area - this is up to franchise owner
14. Sound Proofing is optional. The choice of product and location is unto franchise owner as needed by local code and/or landlord requirements



# RETAIL DESK CONSTRUCTION

## Top View

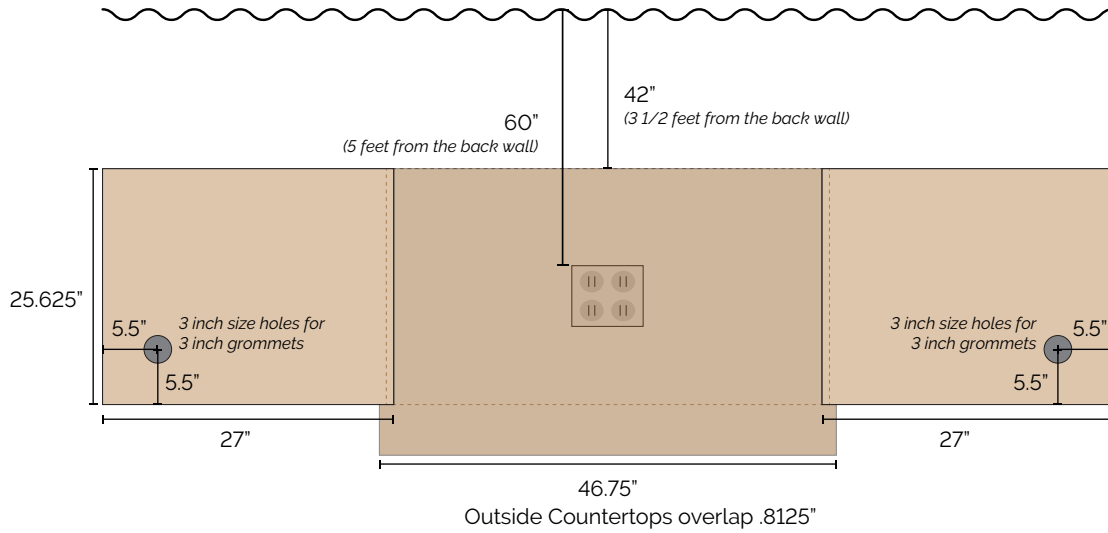

## View Facing From Front Door

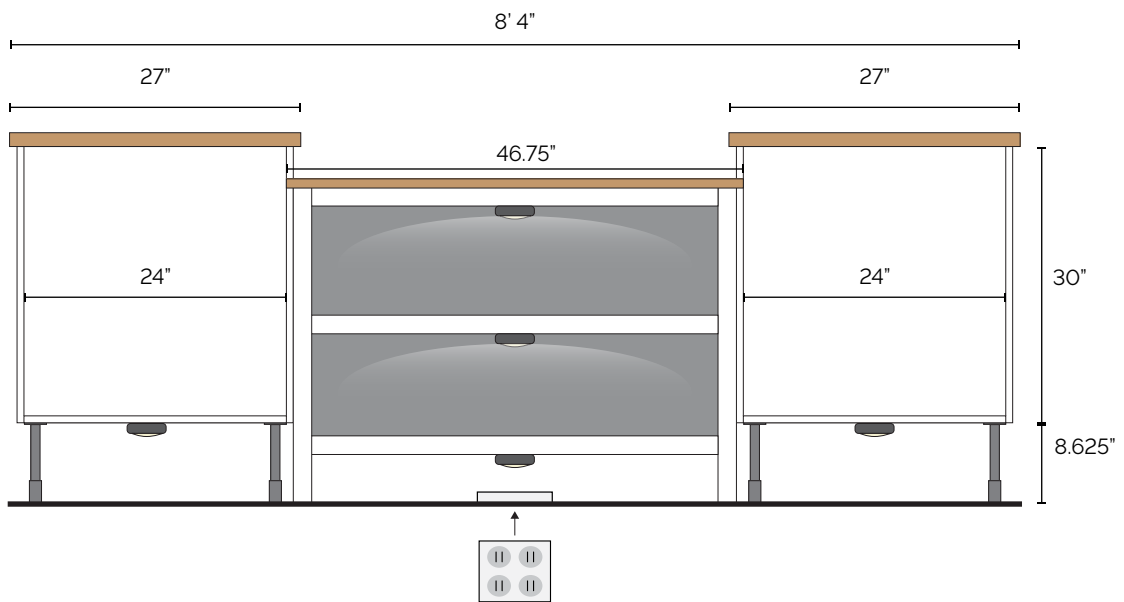

Single outlet centered with 4 outlets  
Horizontal Centering

# CYCLE DOG PLANOGRAM

## Splash and Dash Cycle Dog Wall - Two Section

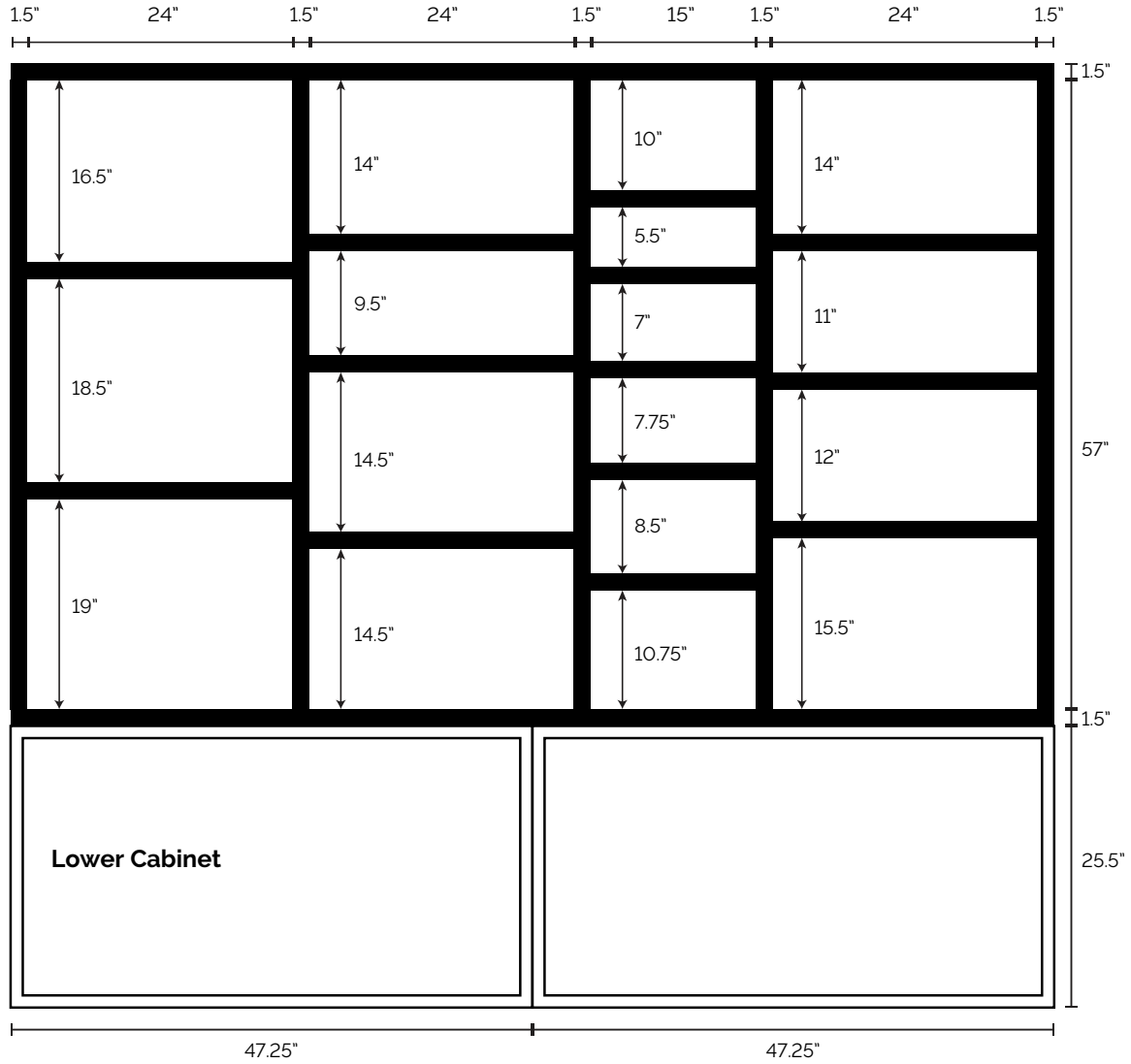

**Cut wood pieces:**

5-14.75"  

8-24"  

5-57"  



2-94.5"  

**Hardware:**

- 44 "L" Brackets 15" with screws.
- 146 Screws, long #8 - 2.5"

# SPA WALL

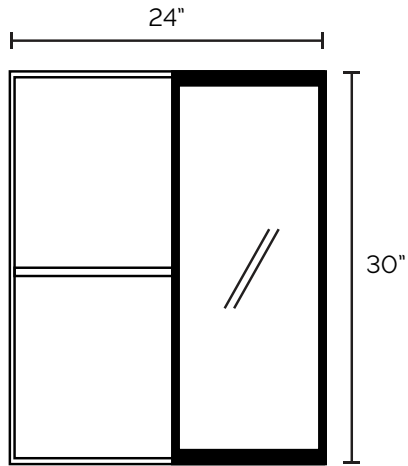
Sink, Base Mirror



Shelves

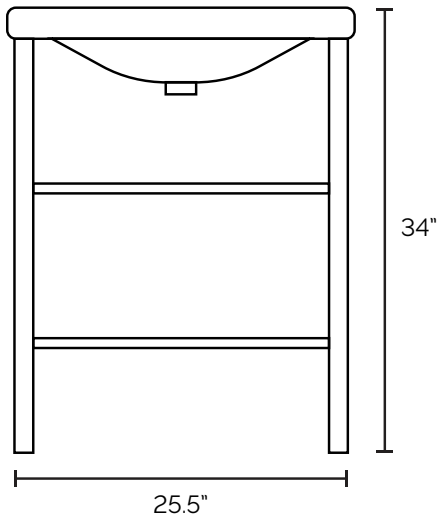
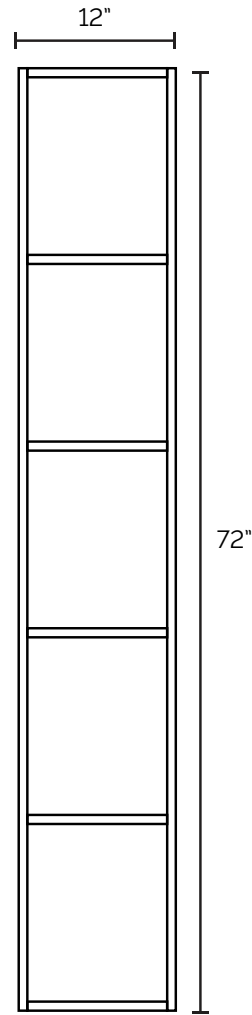

Depth: 16"



Depth: 12"

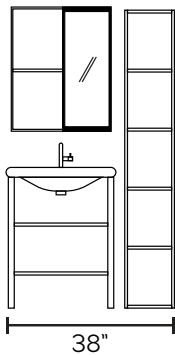

- Sink, Base White, 24x18x24
- Sink
- Bath Faucet, Chrome
- Hook, White 2pk
- Rail for Hooks, White
- Wall Frame, White
- Hanging Mirror for Frame
- Sink, legs for frame 8in 2pk
- Shelves Tower White, 12x12x72

# NESTY TABLES

## Nesting Tables

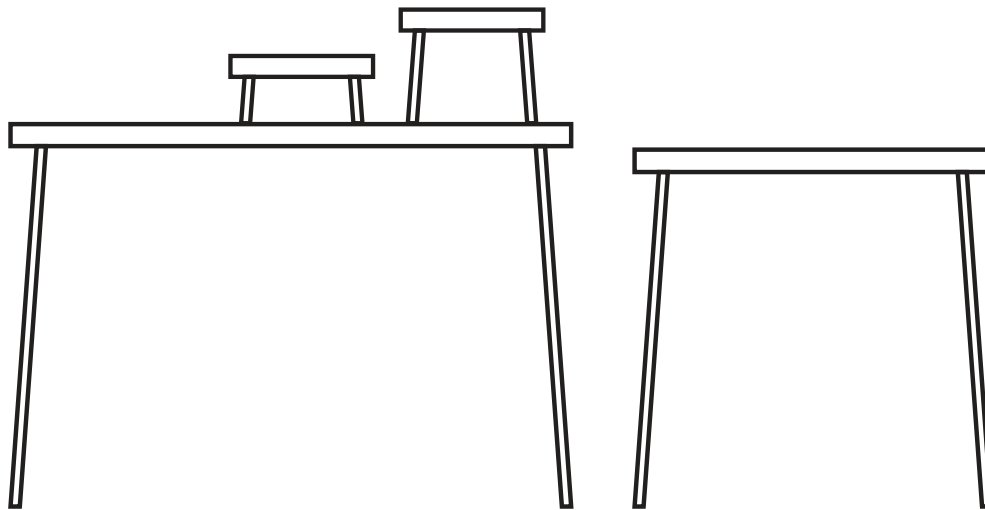
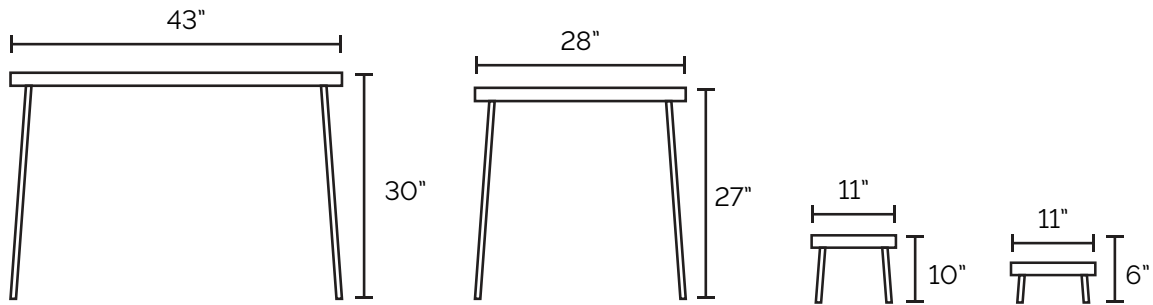

**Notes:** 1 set of table to left and right of the front door

# FUN & FABULOUS WALL

Shelf, white



Bookcase



Gridwall Panels

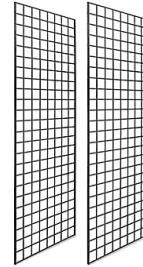

Shelf, white



Bekant Tabletop 47.25" x 31.5"

Gridwall 6"



Table Legs

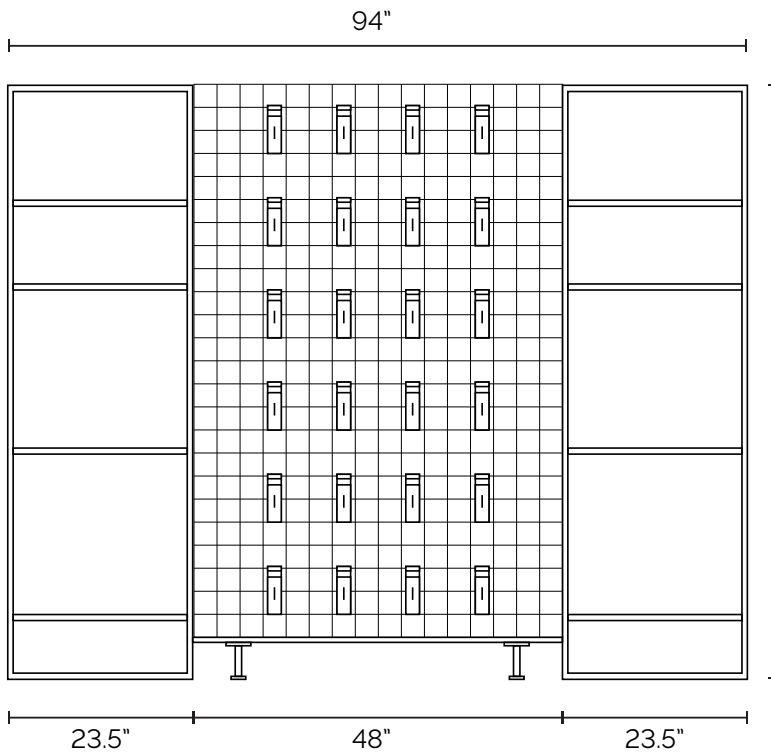

Depth of each side frame: 15.75"

75"



Depth of shelf: 31.5"

# FUN & FABULOUS WALL

Gridwall Panels

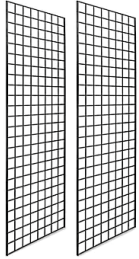

Bekant, white



Gridwall 6"





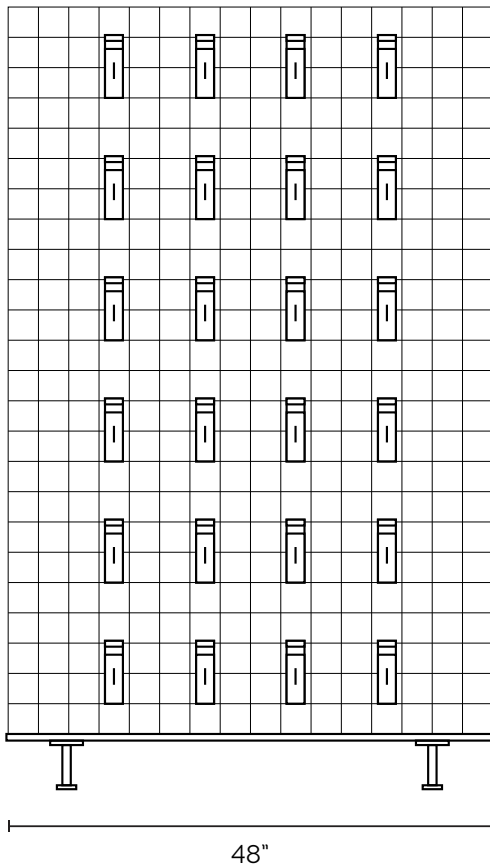













Floor Table Legs



75"



# TREAT WALL PLANOGRAM

4 Inch Hook 3 Bags								
6 Inch Hook 3 Bags								
6 Inch Hook 3 Bags								
6 Inch Hook 3 Bags								
6 Inch Hook 3 Bags								
6 Inch Hook 3 Bags								
6 Inch Hook 3 Bags								
4 Inch Hook 3 Bags								



# SELFIE WALL

**Retail Selfie Wall: 4'x7'**

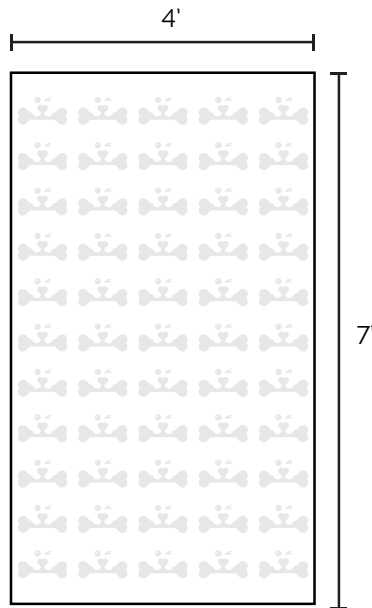

**Service Area Selfie Wall: 4'x4'**

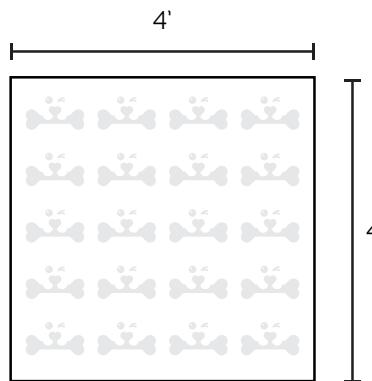
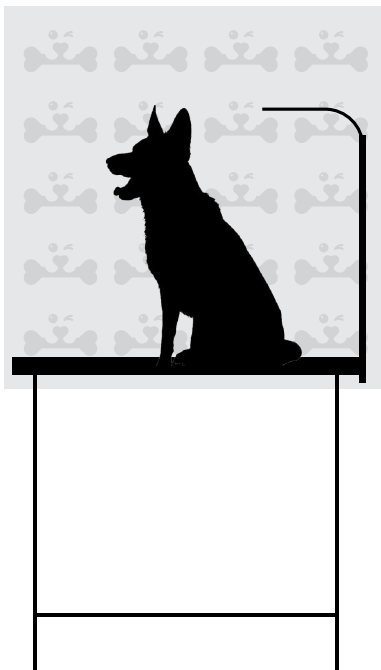

*\*Installed by franchise owner*



# GROOMING STATION

## Front View

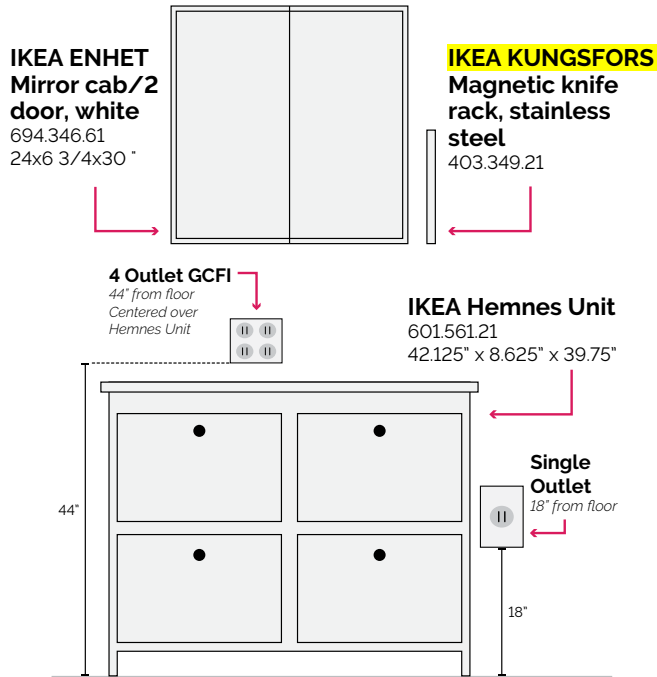

## Reference



## Front View (3 Work Stations)

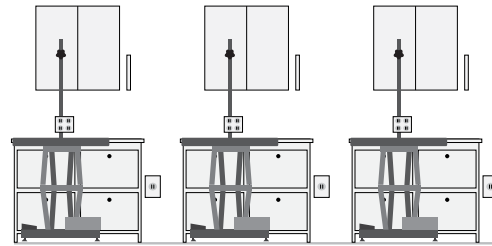

Splash and Dash Grooming Table



Ikea ENHET Mirror cab/2 door, white



IKEA KUNGSFORS Magnetic knife rack, stainless steel



Ikea Hemnes Unit



Notes: Shops under 1200 sq ft: **3 stations**  
Shops over 1201 sq ft: **4 or more stations**

# GROOMING STATION

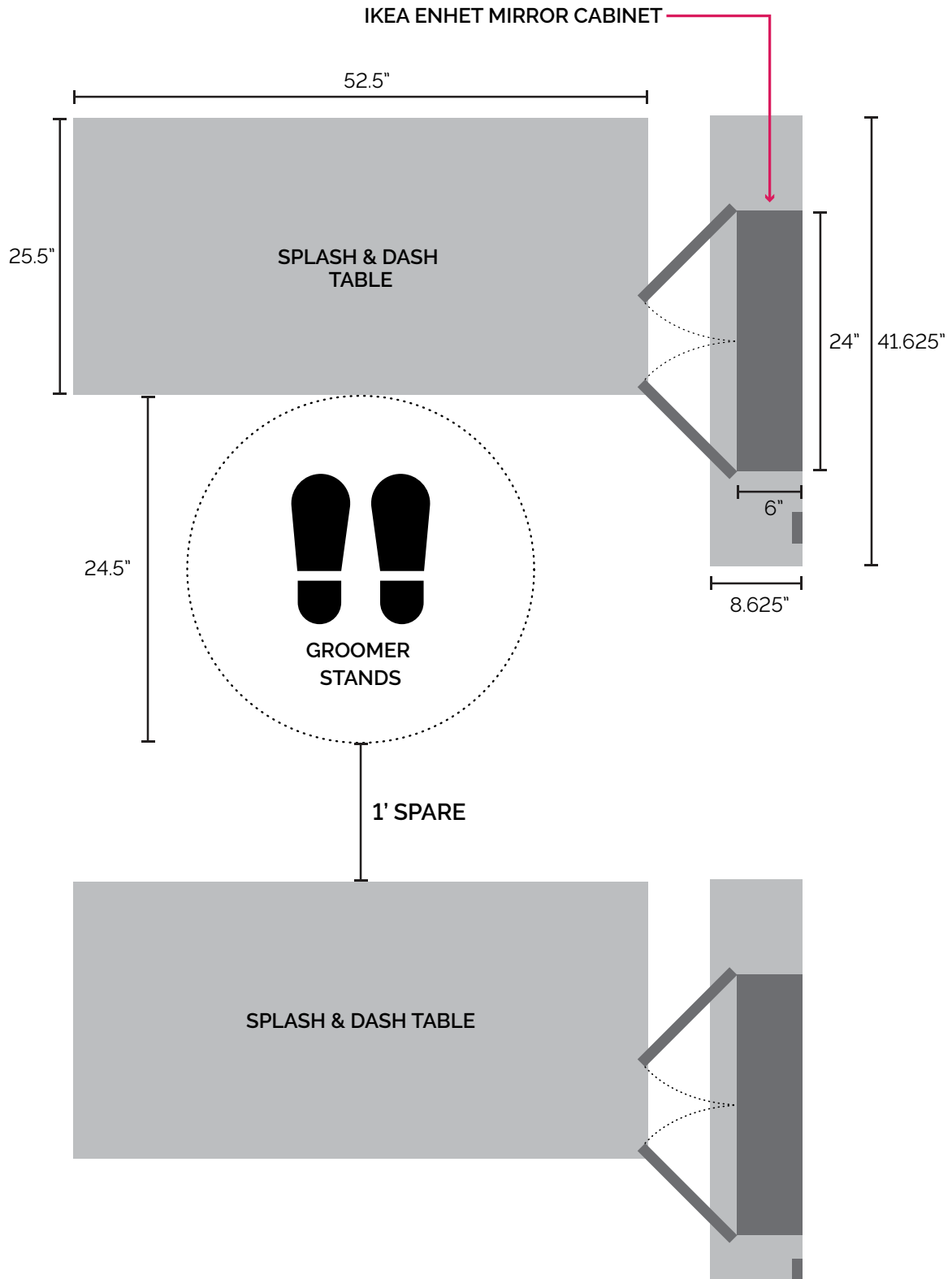

# CAGES SIZES Single Size For Cage Bank Kit



**Small:**  
W: 18.625"  
H: 21.25"  
D: 22.125 "



**Medium:**  
W: 23.25"  
H: 31.125"  
D: 26.125 "



**Large:**  
W: 46.5"  
H: 33.25"  
D: 26.125"

# CAGES BANKS Cages Configuration

Notes: Configuration to be determined during test fit

**6 Bank:** W: 93" x H: 64.375"



**3 Bank:** W: 46.5" x H: 64.375"



**9 Bank:** W: 55.875" x H: 63.75"

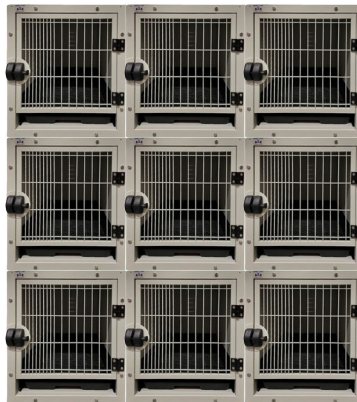

**6 Bank:** W: 37.25" x H: 63.75"



**3 Bank:** W: 18.625" x H: 63.75"



# WIRE FRAME 4 Unit Cage

## Modular Cages

**Small:**  
W: 43.375"  
H: 29.375"  
D: 28.5"

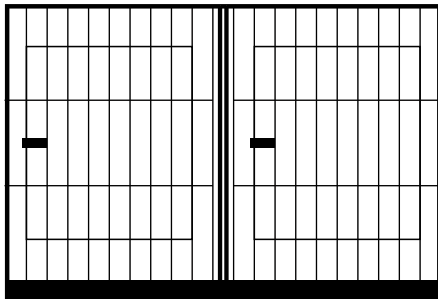

**Large:**  
W: 43.375"  
H: 35.5"  
D: 28.5"

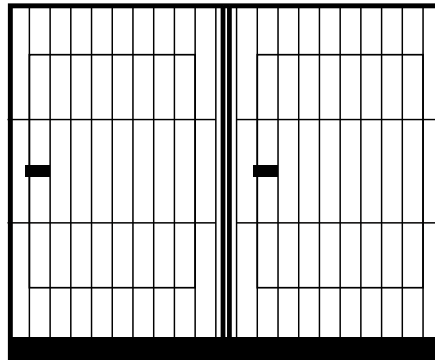

43.375"

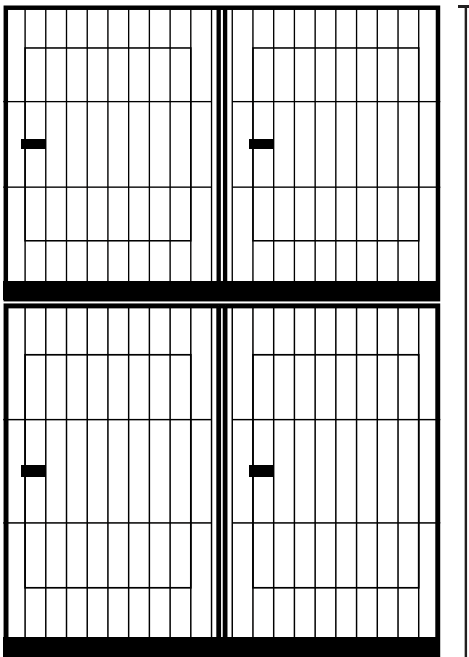

64.875"

Kit includes two regular size Modular Cages with wheels

Modular Cage Bank consists of two regular sized modular cages for dogs. Each cage bank comes with a rolling cage base for easy transport. **Each cage has a divider panel that can be used to separate the one larger cage into two smaller ones.**

# PLUMBER – MATERIALS

## Dura Dog Premier Stationary Stainless Steel Tub (GTU50S)

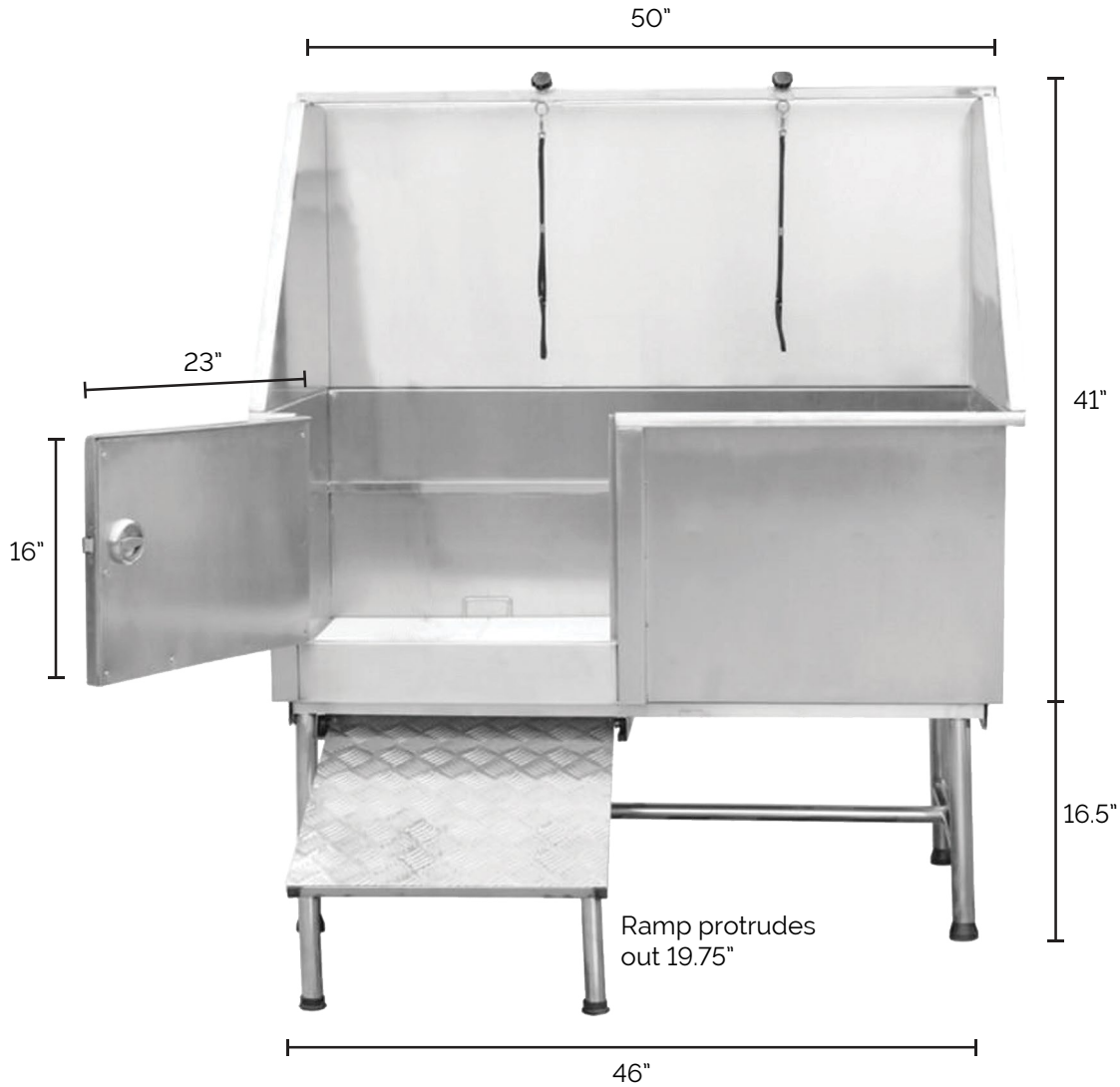

### Plumbing Specs

The drain hole is 3.5" in diameter and is slightly off-centered from front to back in the tub, which puts the center of the hole at 12.5" inches from the front and 12.25" from the back and 14.25" from the side of the tub on center. The three faucet holes are 4" on center. The holes are 1 1/16" in diameter and up 22" from the bottom of the tub itself or approximately 38.5" from the floor. From the backsplash, the center of the first hole is 6.5", the middle hole is 10.5" and the last hole is 14.5".

### Additional Specs

The distance between the faucet holes is 4" and the distance from the welded corner to the last faucet hole is 7.5".

### Notes:

Plan the shop with 3 tubs in mind for when it gets busier. Install only 2 tubs in the beginning.

